

# INDUSTRIAL HEALTH & SAFETY REVIEW

www.isrmag.com

India's Leading Monthly Magazine on Health | Safety | Fire | Security Industry



## SECURING BUSINESSES & BUILDING TRUST



Our customers trust us with the security of their business. We do this with an extensive range of security solutions and analytics. When the business is secured, the trust becomes stronger.

**भारत में बना, भारत का अपना सर्वेलेंस ब्रांड**

**PRAMA INDIA PRIVATE LIMITED**

Office No. 103, F. P. No. 765, Fly Edge, TPS III Junction of S. V. Road, Near Kora Kendra, Borivali West, Mumbai, Maharashtra, India - 400 092.

**Tel** : 022 6896 5500

**Fax** : 022 6896 5560

**Email** : sales@pramaindia.in

**Website** : www.pramaindia.in

# Multi-Door Access Control Solution

with Global Interlock, Global Anti-passback & Global Linkage

**HIGH STORAGE CAPACITY**



InBio Pro C  
Ca



Time Attendance



Access control



Entrance Control



CCTV Surveillance



Elevator Control



Parking Management



Global Anti-Passback & Linkage



Visitor Management



### ZKTeco India Factory

B-1, Khata no. 31, Devasandra Industrial Estate, BBMP K R Puram, Whitefield Main Road, Mahadevapura, Bengaluru - 560048.



Sales



+91 99801 54338

Email ID : sales@zkteco.in



Technical

Contact : 080 6828 1342/48

Website : www.zkteco.in



FR  
Fingerpr

ack

## Access Control Panel



## Controller with Fingerprint & Card Reader Support

### Supporting Readers

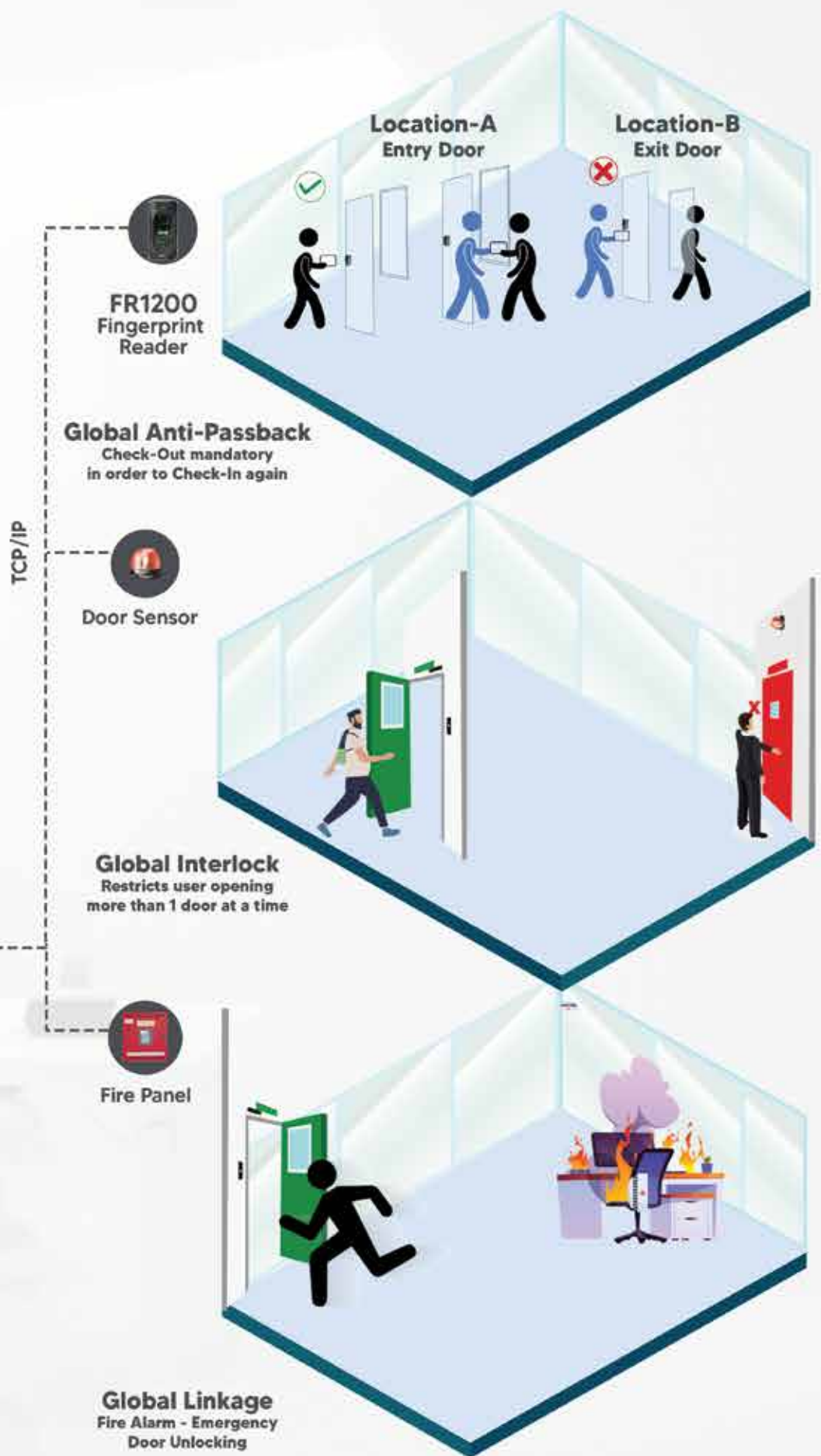



INDUSTRIAL  
SAFETY  
FOOTWEAR

# FOR THE EVERYDAY HERO



TROY



Become a distributor and  
join India's fastest growing  
Safety Footwear brand.



1800-120-0562

7618270270

A quality product by  
**EURO SAFETY**  
INDIA'S MOST PROMISING PPE SUPPLIER

**INDUSTRIAL**  
**HEALTH & SAFETY**  
**REVIEW**

www.isrmag.com

India's Leading Monthly Magazine on Health | Safety | Fire | Security Industry



**KAUSHIK CHANDRAKANT SHAH,**  
 DIRECTOR,  
 VICTOR IMPORTS

**CHINTAN MAHESH SHAH,**  
 DIRECTOR,  
 VICTOR IMPORTS

A LEGACY OF ENSURING  
**HAND SAFETY FOR  
 OVER FIVE DECADES**

PG. 08 - 11



## FROM THE AUTHOR OF SAFESTART AND INSIDE OUT!

12 Paradigm Shifts that are changing the way people view safety regardless of their culture, language or industry.

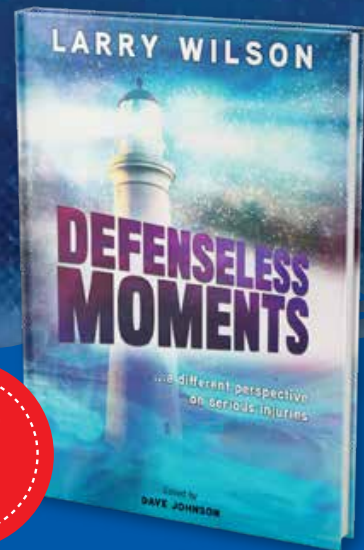

₹ 695  
+  
GST



**ORDER YOUR  
COPY TODAY!**

**DEFENSELESS MOMENTS** provides a different perspective on serious injuries, based on 12 Paradigm Shift articles also authored by **Larry Wilson**.

The book provides a different perspective on serious injuries and addresses risk assessment, unexpected events, safety judgment and skill development, neuroscience, the complacency continuum, deliberate risk and how to handle these issues with a focus on human factors.

The book is a great read and will offer you thought-provoking points ideal for safety discussions and tool-box talks.

# DEFENSELESS MOMENTS

• PODCAST •

Get into the conversation and join our **Defenseless Moments Podcast** today! Tune in to hear the stories behind each chapter of the book, **Defenseless Moments, a Different Perspective on Serious Injuries, from the Author himself!**



<https://asia.safestart.com> · [asia@ssi.safestart.com](mailto:asia@ssi.safestart.com)

Copyright © 2020 by SafeStart. All rights reserved. SafeStart is a registered trademark of Electrolab Limited.

Over the last 20 years, SafeStart has helped thousands of companies in over 60 countries move beyond compliance and beyond the workplace to improve employee engagement and business performance. **SafeStart creates a shift in mindset that has the power to keep people safe at work, at home and on the road.**



### LOOKING FOR ENTERPRISE-GRADE SOLUTIONS TO BOOST YOUR MODERN ORGANIZATION?

Matrix brings to you, a complete portfolio of security and telecom solutions for the enhanced working of your organization. We focus on providing you with technological innovations that provide flexibility, scalability, performance, and reliability. With its versatility and cutting-edge features, Matrix solutions empower your organization to reach out beyond.

-  IP Video Surveillance
-  Access Control
-  Time-Attendance
-  Telecom



Call: (+91) 1800-258-7747  
E-mail: [Inquiry@MatrixComSec.com](mailto:Inquiry@MatrixComSec.com)  
Website: [www.MatrixComSec.com](http://www.MatrixComSec.com)

LET'S CONNECT ON SOCIAL MEDIA! PRODUCT LAUNCH, NEW FEATURES, EVENTS





## From the CEO

### Indian security industry: Growing at the speed of technology

The recent years have seen an increased interest in promoting manufacturing in India. The country's central government has come up with various initiatives that would encourage manufacturing and limit the use of imported products. Many international solution providers who were importing their devices earlier have begun production in the country.

From a technology perspective, India is still adopting video analytics that would allow customers to benefit more from the security systems. Solutions providers and industry experts expect demand for analytics to pick up in the coming year as they become more affordable and valuable.

Automation has proven to be a gamechanger for the physical security industry. Solutions that can work in tandem with each other increase protection and convenience. Cloud-based solutions are also becoming popular among Indian customers, despite concerns about internet and bandwidth connectivity. COVID-19 has created a situation where data management is difficult unless remotely accessible.

Technological advancement and automation can take place only under the backdrop of a robust cybersecurity system. Cybersecurity concerns and related threats have garnered considerable attention from stakeholders and will gain traction in the coming year. State governments in India are increasingly adopting video surveillance equipment to increase security and safety. Kaushal pointed out that the demand for CCTVs is on the rise due to the government's focus on facility security, smart city projects, and healthy building initiatives. The Indian security market will continue to see an increased demand for analytics and innovative solutions to help comply with local guidelines.

CEO



## INDUSTRIAL HEALTH & SAFETY REVIEW

### Publisher

Shilpa Vinayak Kadam

### Editor

Rajeev Iyer

### CEO

Shekhar Dongre

### Editorial Head

P.K. Balasubramanian

### Marketing Team

Ladoji Pendurkar, Amol Powle, Bhavin Shah, Bharat Shah, Sandeep Shetye, Hiren Shah, Reshma Mandal, Rinki Pundir

### Digital Marketing

Kailash P.

### Print & Online Division

Arun P. Shinde, Nandan S. Moghe, Dinesh S. Gawade, Ganesh B. Mahale

### Circulation Executive

Jyoti Fegade, Satish Kadam, Amol Ranshur

**Legal Advisor :** Advocate Vijay S. Jadhav

### BRANCH OFFICES (ZONAL)

#### NORTH

Delhi & NCR regions

Kailash P. : 09552537922

#### SOUTH

Chennai:

Y. V. Raghu : 09566141224

Coimbatore & Kochi

P.K. Balasubramanian :

08451867651

Bangalore & Hyderabad

Amol P. - 09820488541

#### EAST

Kolkata & Eastern regions

Amol Powale -

09820488541

#### WEST

(Maharashtra & Gujarat)

MUMBAI :

Shilpa Dongre -  
09833373371

Reshma Mandal -  
09004354974

#### Pune :

Kuldeep Kshirsagar -  
09689403523

#### Nashik

Abhijit B. Joshi :  
09890002333

#### Gujarat & Saurashtra

Bhavin Shah :  
09702099997

#### Head Office :

Divya Media Publications Pvt. Ltd.,

3rd Floor, Harmony Tower, N.S. Road,

Thane-400 602, Maharashtra

Tel: +91 22-25380574/75,

Telefax: +91-22-25418254

Email: shekhar@divyamedia.com

Website: www.isrmag.com

Printed & Published by Shilpa Vinayak Kadam behalf of DIVYA MEDIA PUBLICATIONS PVT. LTD., Industrial Safety Review, Printed at Anitha Art Printers, 29, Oasis Industrial Estate, Next to Vakola Market, Santacruz (West), Mumbai - 400055, Maharashtra.



# AUTOGLO®

PHOTOLUMINESCENT SIGNAGES

## WE ACTUALLY MAKE DARKNESS VISIBLE

NON PHOTOLUMINESCENT      PHOTOLUMINESCENT

NOT GUARRANTEED      LONG LIFE GUARRANTEED

INVISIBLE IN DARK      IN DARKNESS

NON STANDARDISE SIGNS      AUTOGLO SIGNAGES

### AUTOGLO ECO

## IT'S PHOTOLUMINESCENT

~~NOT REFLECTIVE~~

~~NOT GLOW-IN-DARK~~



NON  
FLAMMABLE



ECO-FRIENDLY  
ONLY



THE LEADING  
ONE



THE TRUSTED  
ONE



THE ORIGINAL  
ONE



LONG LIFE  
GUARRANTEED

✉ sales@prolite.in

🌐 www.prolite.in

☎ +91-22-6786 8100

# CONTENTS

## BUSINESS NEWS

28 - 31

### ENGINEERING EXCELLENCE AWARD

#### 32 Hikvision

Hikvision India Introduces DS-K3Y411X series flap barrier, designed to detect unauthorized entrance

#### 34 KARAM

CRISIL upgrades the Credit Rating of KARAM GROUP

#### 36 PRAMA

PRAMA opens brand store in Aurangabad



## IN FOCUS

### 12

Vehicle Entrance Control Solution To National Thermal Power Corporation (Ntpc) - Lara

## LARRY'S COLUMN



### 24

New Ideas and New Theories: Separating the Wheat from the Chaff Larry Wilson Live with Dave Johnson, former Editor of ISHN By Mackenzie Wilson

## 08

# COVER STORY

A LEGACY OF ENSURING HAND SAFETY FOR OVER FIVE DECADES



## TECH INNOVATION

#### 38 HIKVISION

Hikvision HeatPro Thermal Camera- A Preventive Tool for Fire Safety



#### 44 Ambtronics

Ember Detector: Protecting Process Lines & Conveyer Belts from Fire Risks

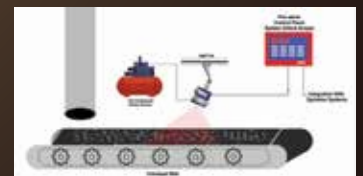

#### 46 Ami Polymer

Does Menstrual Cup affect the hymen?



## PRODUCT SHOWCASE - 54



# CUTS | BURNS | CRUSHING

PROTECT YOUR PRECIOUS HANDS WHILE  
HANDLING HAZARDOUS CONDITIONS AT WORK.

Pick your perfect match from the wide range of Delta Plus safety products



Cut protection



Chemical protection



Thermal protection



Cut protection



Chemical protection



Mechanical protection  
for multi purpose work

CALL TODAY



Your safety at work

+91 88308 58751 | +91 74395 16205

f @ y in t  
www.deltaplus.eu  
sales@deltaplus.in

# CONTRIBUTORS

# EDITORIAL INDEX



**Mr. Farooq Abdullah**  
CEO,  
Marvel Gloves  
Industries



**Mr. Harsha Joshi**  
CEO,  
Prolite Autoglo Limited



**Mr. Larry Wilson**  
Author - CEO,  
SafeStart



**Mr. T. P. Singh**  
Sales Director-India  
Teledyne FLIR



**Mr. Nishith Dand**  
Managing Director,  
Sure Safety India Ltd.



**Mr. Rohit Harjani,**  
Country Manager,  
Indian Sub Continent,  
Hochiki Europe (UK)  
India Branch Office



**Mr. Jiten Mohapatra**  
General Manager - India  
Zkteco Biometrics India  
Pvt. Ltd.



**Mr. Vishal Maheshwari**  
Director (Elmech  
& Digital Access  
Solutions), India/SAARC  
ASSA ABLOY Group



**Mr. P.K. Balasubbra-  
manian**  
President, VBS  
Corporate Support

## A

AMBETRONICS ENGINEERS 44

AMI POLYMER PVT.LTD 46

## H

HIKVISION INDIA 16,32,38,40

## K

KIMBERLY CLARK 12

KARAM GROUP 34

## M

MATRIX 50,56,57

MARVEL GLOVES 48

## P

PRAMA HIKVISION 36

PROLITE 52

## S

SAFESTART 24

## V

VICTOR IMPORTS 8

## Z

ZKTECO 53,54

## CONTACT :

For editorial contributions  
E-mail: editor@divyamediaonline.com

For accounts  
E-mail: accounts@divyamediaonline.com

For advertising materials  
E-mail: advt@divyamediaonline.com

For online advertising  
E-mail: ganesh@divyamediaonline.com

**LIBERTY**

# TECHNOVATE

Innovating the next step in footwear technology



**NEPTUNE**

When your feet feel comfortable and safe then your entire body feels energized. That is what the Warrior All Terrain Professional Gear is all about. Combining innovative design, advanced technology, and superior workmanship they have established their credentials in some of the most challenging work environments as one of the most sought brands of safety shoes.



**Liberty Shoes Ltd.** Warrior Marketing Division, 17th Milestone, G.T. Road, Gharaunda - 132 114, Karnal (Haryana).

Tel: (91) 1748-251120, Board No.: (91) 1748-251111-15 ♦ E-Mail: [inst@libertyshoes.com](mailto:inst@libertyshoes.com), [warrior@libertyshoes.com](mailto:warrior@libertyshoes.com) Website: [www.warrior.co.in](http://www.warrior.co.in)

onThepage.in 20 2022



# A LEGACY OF ENSURING HAND SAFETY FOR OVER FIVE DECADES

(Left To Right : Kaushik Chandrakant Shah - Director, Chandrakant Kalyani Shah, Jitendra Kalyanji Shah, Mahesh Kalyanji Shah, Chintan Mahesh Shah- Director, VICTOR IMPORTS)

Diamond Protech, was founded by a visionary, Kalyanji Virji Shah, the first generation entrepreneur, with the dream of becoming one of India's leading manufacturers of hand gloves. The dream fructified with the starting of its production of household and surgical hand gloves from Dahanu way back in 1968, when there were very few players in the industry. Since then, Diamond Protech grew from strength to strength, up-scaling its operations with a manufacturing facility admeasuring 82,000 sq. ft. and a warehouse space of 27,000 sq. ft. The company forayed into manufacturing, trading and supply of premium rubber hand gloves across a wide spectrum of industries. Its range of offerings today includes household gloves, industrial rubber gloves, acid and alkali proof gloves, electrical shock-proof gloves and finger coats. The company now being managed by the 3rd generation Shah family has grown like a phoenix, spreading its wings in the world of PPE and safety. Excerpts from an interview with IHSR:

**Q. The name Diamond Protech is synonymous with Hand Gloves. How could you achieve this brand image and recall?**

We are on the threshold of our Diamond Jubilee celebrations. Starting our business in 1968, we have come a long way establishing our brand share and creating a brand loyalty with our customers who vouch for our quality and reliability. Our reputation is built on trust emanating from our unwavering and uncompromising quality, commitment and reliability. We have a proven track record of delivering quality products at economical price. So it is our quality and performance which have helped in building our strong brand image over five decades.

**Q. Please throw some light on your beginnings and steady growth?**

Known for manufacturing, trading, and supplying a broad array of premium quality Hand Gloves, Dahanu Rubber Gloves Mfg. Co. started its operations in 1968. We offered a range of products including Rubber Hand Gloves and Jyot Shock-proof Hand Gloves. These hand gloves are well-known in the market for their smooth texture, exceptional finish and resistance to moisture. These are used in various industries for hand safety, and are acknowledged for their resistance to extreme temperature, oils and chemicals. Offered by us at pocket-friendly prices, these products are highly appreciated and demanded by our customers at large. In order to meet the exacting requirements of our customers, we are offering these products in a number of specifications.

**Q. Could you tell us more about your production facilities and manufacturing excellence?**

We have our factories in Dahanu and headquarters in Mumbai. Banking on our huge production capacity, we have been able to cater to the bulk demands of the offered products in the most effective and efficient manner. We follow the best manufacturing methods. Before the final dispatch of these products, the hand gloves are packed with tamper-proof packaging to avoid damage during transportation. In addition, the gloves are made out of quality approved production material in strict adherence to the industry approved parameters. Under the eminent stewardship of our mentor, Kalyanji Virji Shah, we have been able to meet and exceed the expectations of our customers. For smooth conduct of our business related operations, we have divided our facility into various functional departments. This has enhanced our operational efficacy and efficiency.

**Q. Your offerings also include imported gloves. What are the different types of gloves you import, and for what applications?**

In the year 2010, with a view to expanding our business, we established a separate division (Victor Imports) for importing a large variety of rubber hand gloves. Within a year, the company became one of the largest importers of household examination and surgical gloves in India, while also being an OEM for more than 50 brands. Being the only company in its segment to deal in medical and industrial hand gloves in large volumes, the division today has a per day packing capacity of more than 30,000 pairs of gloves. The company brings to India, cutting-edge protective hand gloves from countries like Malaysia, Thailand, Vietnam, Indonesia and Sri Lanka.

Over 50 years, three generations of the Shah family have turned Diamond Protech into India's largest and most reliable



manufacturers and importers of premium quality protective hand gloves. Adhering to strict quality standards, Diamond Protech enables thousands to work with safety hand-in-hand.

**Q. Besides surgical gloves, you also have gloves for a number of applications in healthcare, pharmaceutical and food industry – Right?**

Indeed we have a plethora of gloves for hospital and healthcare work. Our exclusive range of Examination Hand Gloves consists of powdered and powder-free Latex gloves - mainly powder-free Nitrile and Vinyl examination hand gloves – available in a variety of lengths and palm sizes. These disposable gloves offer great dexterity, tactile sensitivity and puncture resistance as well as liquid and gas resistance. While the powdered Latex variants are designed for the economy segment and may contain proteins that cause allergic reactions, our powder-free protein-free Latex and Nitrile variants are non-allergic ambidexterous and offers an incredible grip for dealing with medical instruments. Our powder-free Vinyl Examination Hand Gloves are food grade and perfect for any work related to food industry.

**Q. What are the different kinds of gloves you offer for industrial applications?**

An essential piece of safety equipment for industrial, construction and even agricultural work, our Industrial Rubber Hand Gloves come in soft quality variants, providing exceptional palm grips for better handling. These are specially flock-lined for sweat resistance. From being tear-, shrink or puncture resistant, to being skin friendly, chemical resistant and

providing high elasticity, our Industrial Rubber Hand Gloves are tested on several quality parameters to ensure one can work safely with our gloves in hand.

These gloves find applications in light industrial, construction, mechanical, and agricultural work.

For use in chemical industry, we have Industrial Chemical-Resistant Nitrile Hand Gloves. Apart from being chemical-resistant, our Industrial Nitrile Hand Gloves offer great dexterity, puncture resistance and exceptional protection against harmful liquids and gases. These gloves are preferred in the oil and petroleum industry, chemical processing units and in the battery manufacturing industry. They provide holistic protection against abrasions, cuts and snags, and can be used for printing, plating, plant maintenance and for manufacturing electronic components.

**Q. You have also come up with gloves that are shock-proof for the electrical and power sector. Please elaborate.**

Yes, we have recently introduced our Electrical Shock Proof Seamless Rubber Gloves for the electrical and power sector. They come in different classes such as Class 00 to Class 4 depending on the test voltage. These are mainly used in voltage test tables where the voltage varies from 2500 Volts to 40,000 Volts.

Manufactured using advanced machinery and specially compounded Latex that offers excellent dielectric properties, our Electrical Shockproof Seamless Rubber Gloves offer the best protection from domestic and work-related electrical



Products: Household Rubber Hand Gloves | Surgical Gloves | Examination Hand Gloves | Industrial Rubber Hand Gloves | Chemical Resistant Nitrile Hand Gloves | Electrical Shock Proof Seamless Rubber Gloves





Manufacturing facility in Dahanu

hazards. Designed to be flexible, strong and durable, they provide multiple levels of electrical shock protection and ensure professionals across industries that deal with any electric wiring or equipment, and work with safety hand-in-hand. These gloves coming in lengths 385 mm and 410 mm, are a boon to electricians, utility workers, linemen, power generation plants, construction work, electrical contractors, etc.

**Q. Tell us something about your benchmark for quality.**

Our products are of impeccable quality and workmanship. They are manufactured in controlled atmosphere in accordance with the relevant standards and specifications, and certified by SGS. If you take our Electrical Shock Proof Seamless Rubber Gloves for instance, each and every glove is tested in our laboratory. These gloves are also tested and certified by ERDA, Vadodara, which is a Govt. Recognized Laboratory.

**Q. What's your vision and mission?**

All our operations have a bearing on our core values such as Customer Safety, Comfort & Convenience, Social Responsibility and Trust, Reliability & Quality.

Our Vision is to be one of India's best and most trusted PPE providers, helping to create safer and accident-free work environment all over.

Our Mission is to provide consistently high quality protective gloves at the best prices; To work towards providing products with '0' defect; To provide timely delivery to our customers; To create an automated system for inventory management and to make optimum use of available resources and technology.

**Q. How do you look at the future of Diamond Protech?**

Personal protection is of paramount importance in a work environment especially in today's context. Safety industry, which is a priority sector today, is on a growth trajectory. Naturally, the demand for PPE will increase in leaps and bounds. All this is good news for our business and we do envisage a bright future. **ISR**

For more information  
<https://diamondprotech.co.in/>



# Safety no longer an option, it has become an imperative

## Q. Kimberly-Clark Professional is a leader in PPE. Could you share some of your milestones & achievements?

Kimberly-Clark Professional™ is part of Kimberly-Clark Corporation, a US\$ 19 Bn multinational corporation. Kimberly-Clark is celebrating 150 years of its existence this year. The organization operates in 175 countries across the globe and has a leading market share in 80 countries. It has been a long journey and the company has been the pioneer in multiple product domains like world's first Sanitary Napkin (Kotex), world's first Facial Tissue (Kleenex) and world's first Disposable Training Pants (Huggies). More recently, our wiper product brand WypAll® has been recognized by The Economic Times Emerging Consumer Brands 2020 platform.

## Q. What precisely is your niche?

Kimberly-Clark Professional™ is into personal care, hygiene and safety solutions.

At Kimberly-Clark Professional™, we create full-service solutions tailored to your needs and leverage our unmatched portfolio of trusted brands to elevate the way people experience your business and what it stands for.

## Q. Could you portray your product portfolio?

Our product portfolio includes:

### HYGIENE AND CONTAMINATION CONTROL

We deliver leading-edge hygiene and cleaning solutions for the workplace and washroom from trusted global brands such as KLEENEX®, SCOTT®, etc.

### PERSONAL SAFETY (PPE)

Our range of ergonomically designed PPE solutions and diverse market-leading safety products including Apparels, Gloves, Eyewear & Masks. KLEENGUARD™ and KIMTECH™ products are so comfortable that they encourage the wearer to get the job done more safely and efficiently.

### WIPING

We are a leader in industrial and scientific wiping market, offering wiping solutions that reduce the risk of cross-contamination and drive productivity across industries. We provide WYPALL® Wipers for use in manufacturing



Gaurav Dubey - General Manager, South Asia  
Kimberly Clark Hygiene Products Pvt. Ltd.

environments for clean, consistent performance; and KIMTECH™ Wipers for delicate and critical wiping in labs, as well as other controlled environments.

## Q. Please share details of the key products you introduced recently. And any new products in the anvil?

I believe, as a consequence of the pandemic, the industry is witnessing one of the biggest paradigm shifts in recent times. I foresee this leading to much more concrete SOPs of self-sanitization, more systems coming into place for equipment disinfection, etc. The health of the workforce should and will assume an even higher position in the priorities of the organization. As a responsible industry leader in safety and hygiene products, we plan to encourage and promote this habit by introducing more innovative products.

We have been ramping up our product portfolio while keeping the market needs in mind – both for the present and future. I am also very excited about our new launches in Scientific & Safety PPE, N95 respirators, Safety Apparels, skincare and specialized wiping offerings.

**Q. What are your strategies to improve the position of Kimberly-Clark Professional in the Indian & global markets?**

The importance of maintaining personal hygiene has been highlighted in all the guidelines issued by the WHO as well as by national, state and local governing bodies. I feel it will be eventually ingrained in the psyche of the Indian populace and may not have to be necessarily forced like the earlier top down approach in organizations. I am hopeful of a much more hygiene conscious society, where personal hygiene and safety is a personal choice and not an obligatory part of a 'SOP set by the management'.



Kimberly-Clark Professional's facility at Chakan, Pune

**Q. What are the major factors affecting your business?**

As compared to the more developed countries, India is still quite a distance away on maintaining good hygiene and



safety practices for the workforce and generally too. Sadly cost still takes precedence over safety and hygiene in most facilities. We still don't understand that 'Hygiene will come at a cost'. However, this is expected to change for the better post pandemic, and as a society it is our duty to percolate it to the grass root level. This habit needs to be developed in the densely populated areas, rural areas and even the slums of urban areas.

**Q. What are the key technology trends that are driving the personal protection industry?**

The pandemic has raised consciousness about the importance of quality in Personal Protection Equipment (PPE) industry. Many customers now understand the issues involved with reusable PPE like laundered garments as they significantly compromise the safety of the wearer and hence there is a shift towards disposable garments. Hopefully, this trend will become stronger in the coming months.

**Q. What is your vision for Kimberly-Clark Professional?**

Kimberly-Clark Professional™ partners with their customers to create exceptional workplaces, making them healthier, safer and more productive. We create full-service solutions tailored to our customers' needs and leverage our unmatched portfolio of trusted brands to elevate the way people experience your business and what it stands for. Our brands including Kleenex®, Scott®, WypAll®, Kimtech™ and KleenGuard™ help you make an impact on the people who matter most to you.

I am a firm believer of the 'Make in India' philosophy. Over



the last few years, we have localized the production of many of our products and it has really helped us cater to our customers' needs efficiently and effectively. Most of our paper products are sourced and packed locally. Other products like wipers are imported in bulk form and converted into finished goods in India. We are supported by a converting facility dedicated for our products in Chakan (Pune) in addition to which we have two distribution centers in Pune and Bangalore.



programs, awareness initiatives, reliable after-sales support, robust certifications and claims support for audit purposes. We do a lot of activation and awareness programs in offices and production facilities all over India to promote hand hygiene, specialized wiping solutions and professionally designed protective coveralls to help them create safer, hygienic, and more productive workplaces. **ISR**



Kimberly-Clark Professional's facility at Chakan, Pune





**KLEENGUARD™**

POWER YOUR PRODUCTIVITY



# GENERAL PURPOSE NITRILE GLOVES

## G10 2PRO™ Blue Nitrile Gloves

- Durability and Strength for the most demanding light-duty tasks
- 6 mil finger thickness, 9.5 inches long, Ambidextrous

## G10 Comfort Plus™ Blue Nitrile Gloves

- A balance between Strength and Tactile sensitivity
- 4 mil finger thickness, 9.5 inches long, Ambidextrous

## G10 Flex Blue Nitrile Gloves

- Thin mil gloves for your light-duty tasks
- 3 mil finger thickness, 9.5 inches long, Ambidextrous

### Applications

Aerospace manufacturing, Transportation & Distribution, Food processing, Food-service, Small parts handling, Light duty manufacturing, Janitorial / General maintenance, Precision electronic assembly

PLEASE CALL OUR  
TOLL FREE NUMBER  
**18002660730**  
USE CODE **Gloves-10**

LIMITED OFFER

TO  
GET UP TO  
**10%**  
DISCOUNT\*

**Comply with FDA regulations** for materials used in food contact applications.

AMBIDEXTROUS GLOVES

TEXTURED FINGERTIPS

**Touchscreen compatible** for uncompromised safety & productivity.

\*Discount mentioned is on the List Price of KleenGuard G10 Flex, G10 Comfort Plus and G10 2PRO Nitrile Gloves (subject to terms and conditions and stocks availability).



® / ™ Trademarks of Kimberly-Clark Worldwide, Inc. or its affiliates. © KCWW

Toll Free Number: 18002660730 | Email: [customercare.india@kcc.com](mailto:customercare.india@kcc.com) | Website: [www.kcprofessional.co.in](http://www.kcprofessional.co.in)

# Security and safety in large venues: how smart video can help

By Hikvision India

**K**eeping visitors safe is the top priority for any large venue. However, with expansive areas to cover, and sometimes millions of visitors a year to look after, manual patrols and security video management are the major challenges these places are facing. To address them, leading auditoriums, arenas and stadiums around the world are deploying smart video solutions that can automate routine security checks and trigger alerts in real time in the event of an accident or other incident, helping security staff respond faster and more effectively.

## Security and safety challenges at large venues

At large venues and sports stadiums, large numbers of visitors increase the likelihood of crowding, accidents, and fire safety risks. For these reasons, the security staff has to constantly keep an eye on all areas of the site. However, the sheer scale of these kinds of sites makes this very difficult, or even impossible, to use traditional manual approaches and patrols to protect the entire complex.

## The better way: an automated, large-scale, smart video solution

One way for auditoriums, arenas and stadiums to protect staff and large crowds of visitors is to deploy smart video solutions. These keep track of large areas in high definition and generate automated alerts in the event of accidents and emergencies, helping security teams to assist visitors far more quickly. The leading smart video solutions also provide 'tags' in video footage that allow security teams to search for, and find, footage of incidents much more quickly, which help to deliver further time savings.

Outside large venues, smart video solutions with license-plate recognition (ANPR) capabilities can be deployed to control vehicle access and to help large numbers of visitors to park more quickly. This supports better security and safety outcomes, while



also improving the visitor experience, especially during popular events.

## Excellent results at Zayed Sport City

Zayed Sport City, which is the number one sports destination in United Arab Emirates (UAE), is a great example of how smart video can improve the safety of sports fans and visitors. The venue, which welcomes 1.7 million visiting sports fans each year, has deployed a Hikvision solution that incorporates more than 600 smart video cameras with different functions and types, deployed across the entire site. This includes coverage of the Zayed Sport City stadium, ice rink, bowling center, tennis center and a range of other sports facilities.

With the Hikvision solution, many routine security tasks can be handled automatically, reducing the risk of missed incidents, speeding up responses, and reducing staff workloads and costs. "The Hikvision system's AI features are very valuable in investigating incidents, and it reduces the time required by our staff significantly," says Khalid Al Mutawa, Director of Operations for Abu Dhabi Entertainment Company, the company that manages and operates Zayed Sport City, "Streamlining our processes with this system has allowed us to become much more efficient in ensuring both safety and customer experience throughout the complex. The automated security alerts and the HD Video helps us to respond quickly and work with peace of mind." 

**HIKVISION**<sup>®</sup>

See Far, Go Further

For more information  
[www.hikvisionindia.com](http://www.hikvisionindia.com)

# DIELECTRIC BOOTS



Our new Di-electric Class 3 Safety Footwear provides protection to a maximum working voltage of 26.5kV confirming to EN 50321-1:2018. They are suitable for use in environments with a maximum working voltage of 26.5kV. They are designed to keep you safe and comfortable when working in environments with high voltage hazards.

**Features:**

- Light-weight design
- High-visibility green HV3+ compound shaft on a slip-resistant vulcanized rubber sole.
- Ideal for power and substation operations, electrical installations and electrical hazards in wet conditions.

## OUR RANGE OF DI-ELECTRIC BOOTS:



### Di-Electric Overboots

An electrically insulating dielectric overboot approved to current European standards with a vulcanized rubber sole for superior slip resistance. The Respirex dielectric boot provides protection of up to 20kV over the complete boot for 8 hours.



### Hazmax Boots [With Steel Toe Cap]

An electrically insulating dielectric overboot approved to current European standards with a vulcanized rubber sole for superior slip resistance. The Respirex dielectric boot provides protection of up to 20kV over the complete boot for 8 hours.

YOUR OEM PARTNER  
FOR HIGH FIRE RISK AREA  
DETECTION & SUPPRESSION

**AGNI CONTROLS  
CHENNAI**



## Detection & Extinguishing System for Machinery & Industrial Area

### Protect your

- \* Dust Collector/ Filter Chamber
- \* Server Room
- \* Industrial Dryer/Fryer
- \* Indoor/Outdoor Transformer
- \* Electrical Substation



### Protect your

- \* UPS & Battery Room
- \* High Speed Cutting/ Grinding Machines
- \* Switch Room
- \* Generators
- \* Gas Turbines

### PROTECTING SMALL MACHINERIES

**balawa**® SERIES... Detection & Control Unit

#### Suppression Agent -

- ☆ CO<sub>2</sub> Gas
- ☆ Inert Gas
- ☆ Clean Agent Fk-5-1-12

COMPACT

STYLISH

EFFECTIVE

## FIRE DETECTORS FOR ENVIRONMENTALLY CHALLENGING AREAS

**fladet**® SERIES...

FLAME / EMBER / SPARK / HEAT DETECTORS

**fladet G**® GAS DETECTORS



#### Gas Detector Ranges:

- > IH 765 & IH 838 Series.. **ELECTRO CHEMICAL TYPE** GAS DETECTORS
- > IH 766 & IH 815 Series.. **INFRA RED TYPE** GAS DETECTORS
- > IH 767 & IH 816 Series.. **PELISTOR TYPE** GAS DETECTORS
- > IH 777 & IH 785Series.. **GAS DETECTOR CONTROL PANEL**

Designed in India  
fladet series.. FLAME / EMBER / SPARK / PROBE TYPE HEAT DETECTORS



Manufactured in India

Made to Meet Global Requirement

+91 44 24812420

marketing@agnicontrols.com

+91 7448914999

www.balafire.com / www.agnicontrols.com





# Leave your period woes behind. Say 'YES' to menstrual cup this summer!

- No odor & no stain.
- No more infection & rashes.
- Up to 8 hours of leak-free protection.
- Reusable 5 years.
- Easy to use & easy to remove.
- 100% skin-friendly Medical grade liquid silicone.



# What Are the Most Common Food Processing Plant Hazards?

**A**ccording to the most recent comprehensive economic census, more than 36,000 food and beverage processing plants in the United States employ more than 1.7 million people.

Safety in these sectors is paramount to protect workers and ensure the food they produce is safe to consume. Of the 3 million non-fatal workplace injuries and illnesses in 2016, almost 20,000 happened in the food manufacturing industry.

## What are the most common food processing plant hazards, and how can we prevent them in the future?

### Sanitation Risks

Sanitation is one of the most important parts of food manufacturing and processing. Adhering to the FDA's rules and guidelines is essential to protect employees and ensure food is safe to consume once it leaves the facility.

However, sanitation practices can create risks. Electronics are becoming an increasingly common tool in the food industry, but unless they're properly sealed or designed with a high degree of water resistance, spraying them down with water or solutions can create an electrical shock hazard.

Many of the cleaning chemicals necessary for workplace sanitation are hazardous or even caustic, requiring specialized equipment while in use. Providing comprehensive training and properly fitted personal protective equipment (PPE) can ensure that employees who come into contact with these chemicals are protected.

### Heights

Vertical warehouse and manufacturing layouts are gaining popularity, allowing companies to make the most of otherwise limited floor space. It might be good for efficiency, but spreading up instead of out creates a new safety hazard. Falls from height are among the most common cause of workplace fatalities, to the point that it is included in OSHA's Fatal Four. Working at any height greater than ground level can create the risk of a fall, which increases the need for additional safety measures.

OSHA's fall prevention rules include requirements such as ensuring there are guardrails and toe-boards around the sides of any open or elevated platform. These safety measures are also required for platforms where workers could fall into

dangerous equipment, regardless of the height. Additional fall protection may be necessary for areas where guardrails or toe-boards aren't an option.

### Slips and Falls

Slips and falls are hazardous in any manufacturing setting, but food processing plants present a unique risk. Surfaces are constantly exposed to water and grease, blood and other slippery substances that can increase the chances of accidents resulting in workplace injuries.

Thankfully, some easy solutions can prevent slips and falls in food processing plants. Employees should be required to wear closed-toed non slip shoes to reduce their chance of falling. Keeping the floor clean and dry is the best option. However, when that isn't possible because of the details of the manufacturing process, non slip mats can help fill in some of the gaps and prevent wet floors from creating a workplace hazard.

### Electrical Hazards

Automation in warehouses and manufacturing facilities helps improve efficiency and product quality, but advanced equipment can create its own problems and hazards in the workplace. Working with and around robotics and automated systems requires special attention to worker safety. These devices can't tell the difference between a human hand and the chicken they're sectioning for sale, which could result in serious on-the-job injuries.

Suppose a worker is injured on the production line. In that case, the line must be shut down for sterilization to prevent any contamination that might make the food unsafe. This results in lost productivity and income. Even worse, it can make employees feel like the company is not looking out for their best interests. Situations like these should be avoided at all costs.

Comprehensive training is essential for any new automated systems to ensure no one gets their hands caught in the metaphorical cookie jar. Employees should also be fluent in lockout and tag-out procedures if equipment needs to be taken offline for repairs. Electrocutions are also part of OSHA's Fatal Four, so avoiding situations that could put employees at risk of encountering an electrical hazard is essential.

### Hazardous Chemicals

The chemicals needed for commercial sterilization can be



# 1<sup>st</sup> UL LISTED HIGH EXPANSION FOAM GENERATOR MANUFACTURER IN ASIA



## APPROVALS & CERTIFICATIONS YOU CAN TRUST



HYDRANT VALVE,  
COUPLING & NOZZLE  
MONITORS



CERTIFIED



ON APPROVED  
VENDOR LIST OF EIL



DEFENCE APPROVAL FOR  
VEHICLE ACCESSORIES



MMD APPROVAL FOR  
HYDRANT COUPLING/ NOZZLES



FOAM MONITORS  
INDUCTORS  
LX BRANCHES



LPS 1584 : Issue 01  
Cert / LPCB ref. 2020



HYDRANT VALVE, COUPLING, NOZZLE & MONITORS

HOSE VALVE

INLINE INDUCTOR

LX FOAM BRANCH

FOAM MONITORS

- Landing Valves - LPCB Approved
- Breaching Inlets - LPCB Approved ▪ Hose Valve - UL Listed
- Monitors - UL Listed ▪ Foam Equipment - UL Listed ▪ Handline Nozzles

[www.aaagindia.in](http://www.aaagindia.in)



SINCE 1933

## Shah Bhogilal Jethalal & Bros.

FACTORY & OFFICE : 72, Siddhi Vinayak Estate, Opp. Ramdev Kitchen Express,  
Santej - Vadsar Road, Village : Santej - 382721. Ta. : Kalol, Dist. : Gandhinagar.

Phone : (02764) 268612 - 13 - 14 - 15 • Email : info@aaagindia.in • Web : www.aaagindia.in



AN ISO 9001 : 2015 COMPANY

incredibly dangerous. Chlorine dioxide is often used to sterilize enclosed spaces. It's an effective disinfectant but one that can be fatal if inhaled in any significant quantity. Some safer options are beginning to emerge, such as disinfecting with aerate ozonated water, which acts as an oxidizer. However, they haven't become standard practice in the food processing industry.

The use of fitted and effective PPE is essential to protect food processing workers from the harsh chemicals that are often part of everyday operations. Each person's PPE should fit them as close to perfect as possible. Each piece should be tested regularly before use to ensure it's doing its job. Anything that doesn't work optimally should be repaired or replaced.

Plants may also wish to consider adopting robots or drones for cleaning and sterilization. They can complete the same tasks more efficiently than human workers and do not experience the same risk if they encounter dangerous or caustic chemicals.

### Existing Safeguards

Existing safeguards are designed to prevent workplace injuries or fatalities, but sometimes they may interfere with a worker's

ability to complete their tasks. Removable safety measures can help solve this problem, but this is not always appropriate. Situations where removing them would put employees at risk of encountering blades or moving parts that could cause serious harm should be avoided.

Removing safeguards should never be the first option. Work with your team to help them create operational procedures that optimize efficiency without taking down existing safety measures or making the workplace less safe.

### Keeping the Food Processing Industry Safe

Food processing facilities will become more important than ever as the population continues to grow. These are some of the most common hazards in the food processing industry, but this list isn't exhaustive. Many things can make the operation of one of these plants hazardous to human health. The key is to create a company that actively works to keep its employees safe through comprehensive training, adopting new technologies, and designing best practices that meet or exceed OSHA requirements. **ISR**

## INDIA'S 1ST INTERACTIVE DIGITAL MAGAZINE ON HEALTH, SAFETY, FIRE & SECURITY INDUSTRY

### INDUSTRIES COVERD

- ELECTRONIC SECURITY
- FIRE SAFETY & PROTECTION
- GAS DETECTION & MONITORING
- FIRE ALARM SYSTEMS
- SMOKE DETECTORS
- ACCESS CONTROL SYSTEMS
- BUILDING AUTOMATION
- SURVEILLANCE & IP VIDEO MONITORING
- ELECTRICAL FIRE SAFETY
- MACHINE FIRE SAFETY
- PERSONAL PROTECTIVE EQUIPMENT (PPE)
- INDUSTRIAL PROTECTION



**NEWS | EXPERT OPINIONS**  
**TECHNOLOGY INNOVATIONS | PRODUCT UPDATES**

### INDUSTRIAL HEALTH & SAFETY REVIEW

is India's leading industrial magazine on Health, Safety, Fire & Security Industry, published by Divya Media Publications Pvt. Ltd. which is consistent in delivering quality & authentic contents to the Health, Safety, Fire & Security Industry.

For advertising opportunity contact:  
**shekhar@divyamedia.com | www.isrmag.com**



**Dahanu Rubber  
Gloves Mfg. Co.**

We've Grown Bigger To  
Ensure Your Safety In Better Ways



**DIAMOND  
PROTECH**

WITH SAFETY HAND IN HAND

Building No.3, Krishna Niwas, Khetwadi 9th Lane, Mumbai - 400004, Maharashtra, India  
T: 022 23851299 / 66638666 / 66638111 | E: gloves@rtcogl.in | W: www.victorimports.in



# Production vs. Safety - Ancient Myth or Current Reality? SafeConnection Expert Panel Summary by Mackenzie Wilson

was doing it for production"... the age-old line... and so often the answer a worker gives when asked why they were rushing on the job. But more often than not, as Larry says during the expert panels, we aren't rushing "for production", we are rushing to make up for the time we lost due to a mistake - even if we're not running late. So, while it is still common to find people who think that safety costs time and money but does not increase production or quality, it's hard to argue that reducing human error wouldn't increase those two things. In other cases, this is more or less true - putting a guard on a rotating sprocket doesn't actually make it go any faster, but if that guard prevents an injury that would have resulted in lost time, then it will certainly be beneficial to production. Thus, high-reliability organizations have shifted away from being only production or quality oriented, and focus on more than just the hazards. They do this because they know that reducing human error will likely improve production, morale, and decrease customer complaints and quality problems. The question that remains now, is "how?".

To begin, Larry asks the panelists what they feel in terms of the overall perception around production vs. safety, and if their folks still think the two are at odds with one another. Teg Matthews (Vice President - SafeStart), through conducting his round table focus groups, estimates that about 70% of the HSE professionals he's talked to understand that they still struggle with production vs. safety but will openly talk about what they are doing to work on it, whereas about 20% still have a blind spot in which they don't see any problem. The remaining 10% of individuals come from organizations where safety is genuinely built into the cultural system and thus there is no tension between the two. Similarly, Hector Salazar (Director EHS - Dragados Canada Ltd.) explains that with the field supervisors he works with

in India, 75% feel they are wrestling or conflicted over what is more important between production and safety, or how to go about blending both. Keith Hole (Head of Health & Safety - London Luton Airport) gives us a European perspective and suggests that "about 75% still need to take on [this] journey, 25% get it". In other words, tension between production and safety appears to remain a real issue - all around the world.

With that being said, the panelists still

**“ We drive this concept of safety, quality, environment, operations all [going] hand in hand. You cannot isolate them or their functions - it's internally driven by organized programs by top management. ”**

note that there has been some significant progress in terms of integrating safety into all business processes, and recognizing its importance across the board. As Arun Subramanian (Associate Vice President & Head - HSE, Coromandel International Limited) says, "we drive this concept of safety, quality, environment, operations all [going] hand in hand. You cannot isolate them or their functions - it's internally driven by organized programs by top management." David Bianco (Global SafeStart Program Manager - Epiroc) agrees, sharing that "viewing safety as another 'thing', or a layer on top of everything you do is usually a problematic paradigm... it's really about integrating". He further explains that the technologies they use on the factory

floor have visual management for putting the product together that include safety related considerations and human factors even, like "look for the line of fire", or "this is a heavy object, you could get fatigued". However, Teg explains that sometimes the emphasis on safety that senior management would like is not what's heard on the front line. "We need to make sure the people on the front line understand - that's the alignment and systems piece", he says, "and that they have the skills to talk about safety, how it fits in, and that there is a system of communication within the organization that allows that to go both ways - up and down."

But nevertheless, we cannot deny that culture change takes time. Arun explains that the new generation of individuals coming into the workforce present an opportunity to bridge this gap. "New employees are much smarter, if these programs can be driven to catch them at school level and colleges, you don't just wait for industry to drive safety, environment, and quality but teach the students", he says. Larry agrees, "especially for the habits", he says, "if you learn good habits from the beginning you don't need to unlearn them". But, for an organization to go from production oriented to a balanced, safety focused culture, Ravindra Dhapola (Head Corporate SHE, CSR & Sustainability - Tata Coffee) expects it will probably take 5-10 years, with "top management as a critical catalyst". This time frame was echoed by other Indian panelists, like Arun and Hari Kumar (Director Group EHS Assurance - Emirates National Oil Company)

But what about those who are working with contractors? Certainly, the challenge of getting the message of 'safety as equally important' to a transient workforce would only be magnified. As Hari says, "companies put effort into their organization but don't have the same control over contractors".

He also says that for the last 6 years they have been engaging contractors on LSR, awareness, and stop cards, but 'mindset' is what they would still like to fine tune. At Coromandel, Arun also understands the challenge of working with many contractors. Yet, he believes that "if you can get a number of champions within the organization, you can ease out the challenges for transforming contractors". Specifically, he explains that they kickstart a program for the contractors before they are engaged to help shift from production focus to safety. Then, the 'champions' follow up and monitor them in the field to encourage and guide them. Moreover, he says that all companies start with safety in their meetings - to communicate its importance and have that trickle down throughout the field. To quote Hari again, "every life is equal... culture change is not just your own employees but involves the contractors as well, they might not have the resources for transformation".

The panelists also explain the importance of understanding production's point of view, as well as creating reasonable projections and margins for error. Keith explains that in construction, often the procurement

process (getting the contractors, setting up the project, etc.) can start to drift, and so people who aren't even involved in the actual on the ground construction squeeze the construction time on site - and yet, the client still wants their project completed on time. "We need to educate the client and the people", he says, and Larry agrees. "I think the part about the client is really key", he says, "in order for this to work you have to explain the reality of humanity to the client. You don't want the publicity of opening up your new business on the heels of a tragedy... and you don't want the tragedy. So if something happens like an unforeseen delay either due to our fault negligence or circumstances of force majeure, we have to have an understanding that we mitigate the risk, we don't just increase it". To this end David explains that often when there is a delay we don't use the 'wait time' productively. "There are a number of times we don't have the part we need when we need it, but we know that when we get it and install it it will be out of sequence with what we normally do", he says. "So taking that opportunity and deciding how we're going to do it when the part actually comes in, as opposed to assuming 'my guys know

what they're doing'" is key in his eyes. Moreover, he says that as collaboration between safety and production people gets stronger, "we get a better end result for the workers and for the company".

So while it is still reality that production and safety sometimes butt heads, these panel discussions have shown that collaboration and integration of the two is what is going to achieve the optimal results for both parties. Safety can improve production, and production can assist safety. The two don't need to be mutually exclusive, but it takes maturity to realize that human error is a problem, not just for safety but also for production, quality and customer service. And that it can be minimized significantly by improving the system and training the employees. However, this will take strong leadership, and good communication from top management down to the shop floor to make it work.

ISR

For more information  
Phone: +91 9677060815  
Location: <https://g.page/SafeStart-International?share>  
Mail: [asia@ssi.safestart.com](mailto:asia@ssi.safestart.com)  
Website: <http://asia.safestart.com>

[www.isrmag.com](http://www.isrmag.com)

India's leading monthly magazine on



**HEALTH,  
SAFETY, FIRE &  
SECURITY  
INDUSTRY**

PRINT + DIGITAL

**ADVERTISE NOW !!!**



# UV & Triple IR Flame (Radiant Energy) Detector



With Detector  
Safe Area

Eye is faster than nose  
in the event of live fire.

The  
**UV-IR FLAME DETECTOR**  
responds immediately



Without Detector  
Unsafe Area

PESO Approved  
Enclosure

EN-50270  
EN 61000-6-4  
Compliance

Optional with  
air purging unit



1<sup>st</sup> Time  
in India  
with Bluetooth

## Key Features :

- Multi-Spectral Sensitivity of Flame by using UV & IR sensors.
- Long distance detection & false alarm immunity.
- High sensitivity combined with fast response time.
- Multiple output options - 3 Relays, 4-20mA Output, RS-485 MODBUS compatible.
- User programmable via Bluetooth or RS-485
- Built in self test & test lamp compatibility

## Chemical Industries



## Corrugated Box Manufacturing



Visit Our Factory  
for Live Demo

Manufactured by :



**AMBETRONICS ENGINEERS PVT. LTD.**

Contact : Nahida Shaikh

☎ 022-61673056 📞 +91-93207 37646

✉ sales11@ambetronics.com

🌐 www.ambetronics.com

AMBFLD-3311-AD-26022022

## PADMA SHRI RAMESHWARLAL KABRA BAGS THE ENGINEERING EXCELLENCE AWARD FOR OUTSTANDING CONTRIBUTION TO THE ELECTRICAL INDUSTRY



Padma Shri Rameshwarlal Kabra, the Pioneer and Founder of RR Global, has been bestowed with the prestigious Engineering Excellence Lifetime Achievement Award for his outstanding contribution to the electrical Industry. The event, organized by Divya Media Publications for recognizing 25 outstanding achievers in the industry, was held in Hotel Noorya in Pune on 21st May.

Padma Shri Rameshwarlal Kabra, Chairman Emeritus, RR Global, is the Founder of the 1.2 billion dollar Indian conglomerate, with presence in over 85 countries today.

A philanthropist by heart, and a true nationalist, Mr. Kabra is now involved with All India Tribal Society for the upliftment of Indian tribals and bringing them to the mainstream. [ISR](#)

## PROLITE RECEIVES ENGINEERING EXCELLENCE AWARD FOR BEST INNOVATION IN EMERGENCY LIGHTS



Prolite Autoglo Ltd. has bagged the coveted Engineering Excellence Award for its Best Innovation in Emergency Lights. The event, organized by Divya Media Publications for recognizing 25 outstanding achievers in the industry, was held in Hotel Noorya in Pune on 21st May.

Prolite's Passerelle light embedded on the floor level serves as an Escape Route Guide Marker in high risk areas.

Established in 1984, Prolite Autoglo Ltd. is a leading manufacturer of Emergency Egress Route Lighting Systems and Photoluminescent Signage in the country. [ISR](#)

## ZKTeco BIOMETRICS INDIA WINS ENGINEERING EXCELLENCE AWARD FOR BEST INNOVATIVE PRODUCTS



ZKTeco Biometrics India has won the prestigious Engineering Excellence Award for its Best Innovative Product namely the Biometrics & Access Control Systems. The event, organized by Divya Media Publications for recognizing 25 outstanding achievers in the industry, was held in Hotel Noorya in Pune on 21st May.

Its Biometric and Access Control products & systems are state-of-the art and designed to take safety & security to higher realms.

ZKTeco Biometrics India has been the leading manufacturer of a wide array of Biometric products and provider of a comprehensive range of security solutions in India since 2011.

## MR. RAM AGARWAL, CEO, PROSTARM INFO SYSTEMS RECEIVES ENGINEERING EXCELLENCE AWARD FOR YOUNG ENTREPRENEUR - POWER ELECTRONICS SECTOR



Mr. Ram Agarwal, CEO of Prostarm Info Systems has been bestowed with the Engineering Excellence Award for young Entrepreneur in the Power Electronics Sector. The event, organized by Divya Media Publications for recognizing 25 outstanding achievers in the industry, was held in Hotel Noorya in Pune on 21st May.

Being in the top league of UPS manufacturers in the country today, Prostarm's smart, reliable and energy efficient power electronics solutions are empowering the digital transformation journey of the country.

Established in 2008, Prostarm, under the stewardship of Mr. Ram Agarwal, has grown multifold to serve as a single point provider of power solutions. Prostarm brings clean, efficient, reliable and affordable power electronics solutions across businesses of every size and sector.

## KTA SPINDLE TOOLINGS BAGS ENGINEERING EXCELLENCE AWARD FOR BEST INNOVATION IN 3-DEG HYDRAULIC TOOL HOLDER USING 3D TECHNOLOGY



KTA Spindle Toolings has received the coveted Engineering Excellence Award for Best Innovation in 3-Deg. Hydraulic Tool Holder using 3D Technology. The event, organized by Divya Media Publications for recognizing 25 outstanding achievers in the industry, was held in Hotel Noorya in Pune on 21st May.

Developed for the first time in India using 3-D technology, the toolholder has a slim outer dia to have better access to intricate areas, and improve surface finish while reducing the machining vibration.

In order to enhance profitability & productivity in the milling process, one has to have the right cutting tools and toolholders to support the process. KTA Spindle Toolings, established in 1985, offers performance proven tool holders, bringing significant savings to the user industry. **ISR**

## GLOBUZZ MEDIA WINS THE ENGINEERING EXCELLENCE AWARD FOR BEING THE FAST GROWING CREATIVE AGENCY

Pune-based Globuzz Media Pvt. Ltd. has received the coveted Engineering Excellence Award for being the Fast Growing Creative Agency. The event, organized by Divya Media Publications for recognizing 25 outstanding achievers in the industry, was held in Hotel Noorya in Pune on 21st May.

Globuzz Media Pvt. Ltd. is a powerhouse of strategy, creative innovation, branding and design. Established in 2013, it is a strategy-based consulting media house that works towards helping brands grow. **ISR**



## ATQ METRO RECEIVES ENGINEERING EXCELLENCE AWARD FOR BEING THE FAST GROWING COMPANY IN THE TESTING & MEASURING SYSTEMS SEGMENT

ATQ Metro Pvt. Ltd. has bagged the coveted Engineering Excellence Award for being the Fast Growing Company in the Testing & Measuring Systems Segment. The event, organized by Divya Media Publications for recognizing 25 outstanding achievers in the industry, was held in Hotel Noorya in Pune on 21st May.

ATQ has a large basket of performance-proven Vision Measuring Machines, Cutting Tool Inspection Systems, Auto Quick Measuring Machines and Metrology Fixtures.

ATQ METRO is An ISO 9001 company, ATQ specializes



in Industrial 2D /3D Metrology, Dimensional Measurement, Reverse Engineering and Traceability. It offers a wide range of products for contact and non-contact measurement used in production, quality control, manufacturing and research. [ISR](#)

## REAL TECHNOLOGIES MACHINES WINS THE ENGINEERING EXCELLENCE AWARDS FOR BEST INNOVATION IN INDUSTRIAL COMPONENT CLEANING MACHINES



Real Technologies Pvt. Ltd. has won the prestigious Engineering Excellence Award for Best Innovation in Industrial Component Cleaning Machines. The event, organized by Divya Media Publications for recognizing 25 outstanding achievers in the industry, was held in Hotel Noorya in Pune on 21st May.

Real Technologies is a renowned name in Component Cleaning and Industrial Washing Machines. The company manufactures these machines with advanced filtration & oil removal coalescing systems. Equipped with air blow, component rotation and multi-tier filtration system, it offers these innovative products at competitive rates. [ISR](#)

## MR. VIJAY CHOPDA, FOUNDER & CEO, KTA SPINDLE TOOLINGS WINS LIFETIME ACHIEVEMENT AWARD



Mr. Vijay Chopda, Founder & CEO, KTA Spindle has won the prestigious Engineering Excellence Award 22 for his outstanding contribution to the tool holding industry. The event, organized by Divya Media Publications for recognizing 25 outstanding achievers in the industry, was held in Hotel Noorya in Pune on 21st May.

Mr. Chopda established KTA Spindle Toolings way back in 1969 and transformed it from a precision auto components manufacturer to world's most preferred Indian toolholding company.

Continuous R&D in the company helped in developing several innovative products including 3-deg hydraulic tool holder using 3D technology, and anti-vibration face mill toolholders

He has made a significant contribution to the mission of 'Atmanirbhar Bharat' by changing the mindset of Indian industry and bringing home the fact that Indian companies are second to none in producing world-class quality products. [ISR](#)

## MAIWIR ENGINEERING WINS THE PRESTIGIOUS ENGINEERING EXCELLENCE AWARD FOR BEST INNOVATION IN STEEL COMPOSITE DESIGN, FABRICATION & CONSTRUCTION



Maiwir Engineering has won the prestigious Engineering Excellence Award for Best innovation in Steel Composite Design, Fabrication & Construction. The event, organized by Divya Media Publications for recognizing 25 outstanding achievers in the industry, was held in Hotel Noorya in Pune on 21st May.

The patented Maiwir system comprises horizontal structures and vertical columns which are modular. The beams have trusses encased in carter plate & columns have cages encased in pipes. The slabs consist of lattice girders & EPS blocks that minimize the consumption of concrete. The dead loads are minimal, resulting in less foundation costs & lighter sections.

Established in 2015, Maiwir Engineering has emerged as a prominent force in innovative and efficient engineering design, fabrication and execution under one roof. The company executes complex engineering projects to cater to the needs of the fast growing Infrastructure sector. [ISR](#)

## DELTA ELECTRONICS RECEIVES ENGINEERING EXCELLENCE AWARD FOR BEST INNOVATION IN POWER QUALITY MANAGEMENT

Delta Electronics India Pvt. Ltd. has bagged the prestigious Engineering Excellence Award for Best Innovation in Power Quality Management. The event, organized by Divya Media Publications for recognizing 25 outstanding achievers in the industry, was held in Hotel Noorya in Pune on 21st May.

Delta Power Quality Restorer is designed keeping in mind industrial loads and Indian grid code requirements and to address a plethora of power quality issues.

Delta Electronics is a leading Power & Energy Management company, operating in three business categories viz. Power Electronics, Automation and Infrastructure, with market leadership in Telecom Power, Renewable Energy & Display Solutions. [ISR](#)



## Hikvision India Introduces DS-K3Y411X series flap barrier, designed to detect unauthorized entrance

By Hikvision India



Hikvision India has introduced the latest product DS-K3Y411X series flap barrier in the entrance control product portfolio. This flap barrier with two barriers and 6 pairs IR lights is designed to detect unauthorized entrance or exit. By adopting the flap barrier integrated with the access control system, a person should authenticate to pass through the lane via swiping IC or ID card, scanning the QR code, etc. It is widely used in attractions, stadiums, construction sites, residences, etc.

This Flap Barrier is one of the serial products of entrance solutions from Hikvision product portfolio. It provides secure entrance solutions in various scenarios while ensuring safety and security in the office buildings and public places.

### The key features of DS-K3Y411X series flap barrier

### in the entrance control product portfolio includes following:

- Permissions validation and anti-tailgating.
- Remaining open/closed mode selectable.
- The barrier will be open or stop working when people are nipped.
- Self-detection, Self-diagnostics, and automatic alarm.
- Audible and visual alarm will be triggered when detecting intrusion, tailgating reverse passing, and climbing over the barrier.
- TCP/IP network communication: The communication data is specially encrypted to relieve the concern of privacy leak.
- LED indicates the entrance/exit and passing status.
- Fire alarm passing: When the fire alarm is triggered, the barrier will be open automatically for emergency evacuation



Hikvision Flap Barriers are available in following models - DS-K3Y411I-L1, DS-K3Y411X-L2, DS-K3Y411X-M1, DS-K3Y411X-M2, DS-K3Y411X-R

ISR

**HIKVISION**<sup>®</sup>

See Far, Go Further

For more information,  
[www.hikvisionindia.com](http://www.hikvisionindia.com)

# Group Safety Training Kiosk!



Safety training is an important aspect for the Safety Audits. Work Permit Safety Trainings , GMP Trainings , SOP Trainings are usually conducted with a group of people. Hence using STK GT one can conduct safety training for 30 persons in one go.

It comes equipped with a large display , pre-loaded safety training content and remotes similar to those used in the famous show KBC on television. Users require almost no training to use the system. PPT conversion with voice over, Training scheduling & advance intimation via SMS are important aspects of STK GT.

- 30 Persons can be trained in one sitting.
- Very easy to use remotes for evaluation similar to the KBC show.
- Convert your existing PPTs with voice over for repetitive training.
- Add existing training material on STK GT.

More than 1000+ successful installations.

Call us today to know more about STK GT : Group Training Safety Training Kiosk.



☎ 020 25281608 / 9326727467  
sales@scrum-system.com  
www.scrum-system.com

# CRISIL upgrades the Credit Rating of KARAM GROUP

CRISIL Ratings has upgraded its ratings on the bank facilities of Karam Group to 'CRISIL A/Stable/CRISIL A1' from 'CRISIL A-/Stable/CRISIL A2+'

The company has achieved this upgrade after 3 years of sustained improvement in all financial and business metrics. The upgrade reflects the improvement in the business risk profile of the group driven by higher revenue in fiscal 2022 backed by enhanced demand from the exports market, introduction of new products under health care segment and increased revenue composition under own brand. The group also has strong presence as original equipment manufacturer supplier to numerous safety brands both in India and abroad. The group has strong market position and diversified endues industry base (safety and industrial; health care and retail). It has established itself as a leading manufacturer of personal safety and fall protection safety equipment with strong brand recall.

Despite sluggish demand and lockdown restrictions during the first quarter, revenue posted a 50% year-on-year growth and expected more than Rs 700 crore in fiscal 2022. Operating margin, at 23.0-24.0% in fiscal 2022, is expected at similar levels in fiscals 2023 and 2024, backed by better capacity utilisation and backward integration of operations. The ratings continue to reflect the robust market position of the group and the extensive experience of its promoters in the safety equipment segment. Across India, only 5-10% companies fall under this category.

Speaking on the same, Mr. Hemant Sapra (President, Global Marketing) at KARAM Safety Pvt. Ltd. said, "All the employees and entities of KARAM Group are excited about the CRISIL Ratings upgrades. This will enhance our companies credibility and widen our audiences, it is an important step in our growth & diversification. It reflects our continuous hard work, dedication and better than expected operating performance. We want to keep up the momentum and continue working towards achieving such milestones in

the future."

The Long Term rating of CRISIL A represents that investment in Group is considered to have an adequate degree of safety, it includes timely servicing of financial obligations with low credit risk in Long term. The Short Term rating of CRISIL A1 represents that Investment in Group is considered to have a Strong degree of safety regarding timely servicing of financial obligations with lowest credit risk in the Short Term.

### About KARAM Group:

KARAM is India's one of the leading Personal Protective Equipment Manufacturing enterprises, ranks as the number one company in the field of Personal Safety in the country, and among one of the top ten Fall Protection manufacturing companies in the World. Its product range includes Personal Protective Equipment like safety helmets, safety eyewear, hearing protection, face protection, hand protection, protective workwear, safety shoes, and a vast range of Fall Protection Equipment. Besides these, engineered safety solutions like anchorage systems, specialized rope access, evacuation and rescue products, and confined space entry egress systems also form a part of KARAM's Product Portfolio. KARAM Training and Consultancy is a specialized wing created for providing training and safety consultancy in the field of work-at-height in India. 



### Rating Trend of last 4 years:

Particulars	2018	2019	2022
KSPL - Long Term	CRISIL BBB+	CRISIL A-/Stable	CRISIL A/Stable
KSPL - Short Term	CRISIL A2+	CRISIL A2+	CRISIL A1
PNI - Long Term	CRISIL BBB+	CRISIL A-/Stable	CRISIL A/Stable
PNI - Short Term	CRISIL A2+	CRISIL A2+	CRISIL A1





**MN Rubber Pvt Ltd**  
Mfg. of Safety Hand Gloves

# LEEFIST HANDCARE INDUSTRIAL



<b>Colour</b>	Yellow
<b>Thickness</b>	0.65 to 0.70mm +/-5mm
<b>Size &amp; Weight</b>	10" (135 gms) 12" (155gms) 14" (175 gms) 16" (210 gms) 18" (235 gms) 22" (250 gms)

0075



EN 374



EN 388



\*image shown for representation purpose only

Plot No. 1815, 4th Phase, Wadhwan GIDC,  
Surendranagar, 363 002 (Gujarat) INDIA

Phone: +91 - 99131 02603  
+91 - 96241 12603

Email: [info@mnrubberindia.com](mailto:info@mnrubberindia.com)  
Web: [www.mnrubberindia.com](http://www.mnrubberindia.com)



## PRAMA opens brand store in Aurangabad

India's premier indigenous security and surveillance product manufacturing company, Prama India in association with partner Security Kart has launched its brand store on April 21, at Aurangabad, Maharashtra. PRAMA Brand Store was inaugurated at Samarth Nagar, Nirala Bazar in the presence of leading dignitaries from the security industry. The newly opened PRAMA brand store will help to make latest PRAMA security products available in Aurangabad. Security Kart is a trusted partner of Prama India, it has carved a niche in the security industry by setting a new benchmark.

Located in the northern part of the state of Maharashtra, Aurangabad is famous for Ajanta and Ellora caves. Now the city has the honour of being the first city in Maharashtra to have the PRAMA brand store. The company has planned a pan-India phased rollout of PRAMA brand stores and aims to open multiple stores spread across Tier-I, Tier-II and Tier-III cities over the next 12-month period. PRAMA's new brand store is aimed at showcasing and bringing high quality, state-of-the-art security and surveillance products as well as the latest technology innovations closer to potential consumers and end-users.

"We at Security Kart are elated to be an integral part of PRAMA Brand Store launch in Aurangabad. We are inviting all the stakeholders of the security industry in the Marathwada region to experience the wide range of indigenously manufactured PRAMA security products at our brand store. We will be happy to serve your product requirements by providing it promptly," said Mr. Vaibhav Barman, Partner, Security Kart.

Commenting on this momentous occasion, Ashish P. Dhakan, MD & CEO, Prama India Pvt. Ltd. said, "This grand store opening event signifies our strong presence in the northern part of Maharashtra. It is a glorious moment for all the security professionals associated with Prama India. We are happy to dedicate our first PRAMA Brand Store to the people of Aurangabad. This is just the auspicious beginning of a journey, we will strive for exponential growth and expansion of the brand at a pan-India level. Our store is



strategically designed to showcase best-in-class products and solutions. We are hopeful that the store in Aurangabad will be able to serve the security professionals in the Marathwada region to source the latest PRAMA Security and Video Surveillance Products. We extend our best wishes to Mr. Vaibhav Barman, Partner, Security Kart and hope this initiative will help to create a new success story with PRAMA ecosystem partners."

"While moving forward with the vision of Aatmanirbhar Bharat, we at Prama India are working diligently to realise the dream of a self-reliant India into reality. As the industry moves to new technology frontiers, there is a need to focus on indigenous security product manufacturing. These security systems are helping to resolve the physical security challenges in the private, government and commercial segments," said Mr. Dhakan.

The newly inaugurated PRAMA Store in Aurangabad showcases a wide range of security and surveillance products to create a new customer experience. PRAMA's key USP is to provide customers and end-users with a hands-on experience by sharing insights into myriad vertical solutions, designed as per the considerations of Indian environment and standards framework. Prama India has been working tirelessly to make India self-reliant in the electronic security product manufacturing, the company believes its indigenous manufacturing will be one of the key enablers for achieving India's vision of becoming truly Aatmanirbhar.



Prama India has made significant investments to create a product portfolio that combines cutting-edge technology with the best of innovation and quality from India that put the country on the global map of security and surveillance products. **ISR**





Are you  
looking  
for  
The better  
**Ear Protection?**

Your search is over



**SILICON REUSABLE EARPLUG**  
MC-2001C (WITH CORD)



**DISPOSABLE PU FOAM EARPLUG**  
MC-1003AC (WITH CORD)



**ECONOMIC EARMUFF**  
EM-5003



FOR MORE DETAILS / ENQUIRY PLEASE CONTACT  
**Marvel Gloves Industries**



**Manufacturers, Exporters & Importers of Gloves & PPEs**  
187/188, 2nd Floor, Ashoka Shopping Centre, G.T. Hospital Complex, L.T. Marg, Mumbai 400 001 INDIA  
Tel.: +91 22 22659475 / 22659480 | Phone No: 9987402000 / 7400449905 / 9619453278 / 7400447711  
Email: sales@marvelgloves.com | Website: www.marvelgloves.com

**DEALERSHIP ENQUIRIES SOLICITED**

Follow us on: marvelgloves

# Hikvision HeatPro Thermal Camera- A Preventive Tool for Fire Safety

By Hikvision India



**F**ire is a massive safety concern, especially in large areas with combustible 'elements', such as charging units, waste and battery storage areas. Often these areas are unmanned at all times, and traditional monitoring methods do not always see a fire in time. The speed at which a fire can take hold is frightening, and so the earlier a warning is given, the better the outcome. Thermal technology is coming down in price and is being used increasingly to detect abnormal heat rises, effectively offering a fire prevention solution, rather than a fire reaction one.

## A serious problem smoulders

According to the U.S. Fire Administration (USFA) the US suffers an annual average of 1.3 million fires resulting in 3,190 civilian deaths, 16,225 civilian injuries, \$14.7 billion in direct property loss. It is a great concern to industry too, especially in large buildings with combustible or electronic contents, like warehouses, fulfillment centers, dispatch centers, and datacenters. Even battery charging stations are higher risk, with Lithium-ion batteries being a particular concern.

Existing methods of detection can prove useful, but have limitations with regard to verification and warning time. Smoke detectors will give an alarm when they detect smoke

in the air. However, this is only after the fire has already started. The same applies to air sampling devices, which tests the particulates in the air, although these can usually detect smoke before a smoke detector.

Optical cameras are also used, but they can only give a warning when flames are visible – in other words, when the fire has already started.

## Monitoring temperature before flame

Thermal imagery can give warnings at an earlier stage of a fire. Because this technology monitors the temperature, rather than the output of a fire (smoke, flame, etc.), it can flag a potential issue before it happens. If thermal sensors detect abnormal temperatures, operators can investigate further and take action to avert the fire itself.

Cameras can be positioned at certain points around a site to monitor it all, or used to focus on particular risk points, like a waste dump, or an electric charging station. Solution designers use thermal technology successfully in a number of scenarios, including recycling centers, forests, and warehouses.

## Verification avoids false alarms

Many fire systems use different types of sensor in combination, and thermal technology adds extra value by verifying other alerts. For example, it can double-check the temperature of an area where a smoke alarm has sounded.

Thermal cameras can also provide support for those checking the alert location. With the use of a bi-spectrum camera, operators in the control center can see if the person checking the alert is in the same place as that alert, reducing the chance of error and missing a potential fire risk.

The technology also comes in useful for planning and risk assessment. It can show potential 'hot spots' in a building by monitoring it over time. These can then form part of risk mitigation - to pay particular attention to those areas for fire prevention activities and evacuation plans, for example.

When there are people in an area, preventing fire becomes even more important. Injuries can be averted, even lives saved, if they get the proper warning in time to act - whether to put out a fire or evacuate. Thermal camera ranges (e.g. Hikvision's HeatPro series) have models linked directly to sirens or strobe lights. These can give a general warning in the area of the camera, as well as an alert to the system operator.

### Installation design flexibility

Lower cost thermal cameras, like HeatPro, can also provide great flexibility in building a bespoke system for a site. A number of different detection distance options in the cameras provide different fields of view. This means that installers can

find the right combination to meet the needs of the space they need to protect. Hikvision also has a Thermal Design Tool – software to guide installers on the best way to place the cameras in an area.

Franck Carette, Product manager Europe Security & Safety Thermal Products at Hikvision, says: "The fact the thermal technology has come down in price means that it's now a much more sensible fire prevention option from an economic perspective. With the introduction of our latest model, this makes even more sense, since this has a much larger field of view. This means installers need to put in fewer cameras to cover the same area as before."

The maxim 'prevention is better than cure' resonates well in the world of fire safety. Fires cause massive damage, and can even be responsible for grave injury or death. However, if a fire risk can be identified early enough, a fire can be successfully managed, or avoided altogether. Thermal technology can provide that extra bit of time that makes the difference between containment and disaster. **ISR**



For more information  
[www.hikvisionindia.com](http://www.hikvisionindia.com)

**INDIA'S LEADING MAGAZINE ON  
 HEALTH, SAFETY, FIRE & SECURITY INDUSTRY**

**Connect with the industry**  
 For advertising opportunity contact: [shekhar@divyamedia.com](mailto:shekhar@divyamedia.com)  
[www.isrmag.com](http://www.isrmag.com)



# Keeping cities moving: 5 ways to manage traffic better with smart video

By Hikvision India

Excessive traffic is a growing issue on road networks around the world, and reliance on private vehicles is still increasing. The good news for the authorities is that the latest smart video technologies can help to keep traffic flowing – cutting journey times, increasing road safety, and helping to reduce vehicle emissions, says Juan Sádaba, ITS Business Development Manager at Hikvision Spain.

**C**ity and highways authorities are under huge pressure to manage and, where possible, to reduce traffic volumes on their networks. Not only are road users demanding, fast action on traffic congestion, but regional and national governments are also mandating major reductions in emissions from road transport to meet strict air quality targets.

When it comes to improving traffic management, and overcoming congestion and emissions challenges, city and highways authorities are looking for innovative technologies to help them succeed. One key example is smart video, which allows authorities to understand real-time traffic conditions, and to act more quickly and effectively in the event of an incident or accident.

## Five ways smart video can help

Smart video provides unique insights based on real-time traffic awareness. This helps authorities to tackle their congestion and emissions challenges in five important ways.

### 1. Improve traffic flow and reduce jams

To take effective action on congestion, the authorities need a clear view of traffic load at different times of day, on busy corridors, and at major junctions.

Smart video provides this critical insight by counting vehicles continually, and by triggering alarms when queues develop, or when traffic volume exceeds pre-defined thresholds.

With a real-time view of traffic, authorities can implement a wide range of initiatives to reduce congestion, from increasing charges at certain times of day, to rerouting traffic during busy periods in collaboration with navigation providers.

### 2. Maximize road (and driver) safety

With smart video, alerts can be triggered automatically in the event of an accident. This allows emergency teams to respond faster, and dispatch the right vehicles and crews to the scene based on specific circumstances and needs – which all helps to improve outcomes for drivers and passengers.

The leading smart video solutions also offer more specialized road safety solutions, such as safety monitoring solutions for road tunnels. Here, AI-enabled cameras offer Automatic Incident Detection (AID) for vehicles traveling the wrong way through tunnels, pedestrians in traffic lanes, obstacles in the tunnel, the presence of fire or smoke, and a range of other hazards that put motorists at risk.

### 3. Optimize traffic planning

With smart video, authorities can monitor traffic flows over days, weeks, months and even years to support data-driven

planning decisions. This is enabled via AI-powered cameras that support accurate vehicle counting and video data analytics.

In the short term, video analytics allow authorities to identify and address traffic bottlenecks by redesigning junctions or rerouting traffic. In the longer term, it's possible to plan new infrastructure projects that ease congestion, or to implement congestion charging schemes or other traffic management measures that reduce demand at peak times.

#### 4. Improve violation enforcement

The latest smart video solutions automatically detect traffic violations, such as forbidden turns, speeding, incorrect use of lanes, vehicles traveling the wrong way in a lane, and illegal parking. Alerts for these and a range of other infractions are generated automatically and forwarded to traffic authorities in real time, supporting faster and more effective responses.

As an additional benefit, smart video solutions that support license plate recognition can determine if vehicles are properly taxed and insured by cross referencing their details with local

authority databases. This makes it possible to identify stolen and uninsured vehicles, reducing risks to other road users.

#### 5. Support fairer and more effective congestion charging and tolling schemes

AI-enabled smart video solutions can help authorities to apply tolls and charges more fairly based on the characteristics of individual vehicles. This means, for example, that drivers of cleaner vehicles can be charged less, and that more polluting vehicles can be charged more, or prevented from entering restricted traffic areas at busy times.

As an additional benefit, AI-enabled smart video solutions can support dynamic pricing, with higher charges applied when traffic volumes exceed pre-defined levels. **ISR**

**HIKVISION**<sup>®</sup>  
See Far, Go Further

For more information  
[www.hikvisionindia.com](http://www.hikvisionindia.com)



**Divya Media**  
PUBLICATIONS PVT. LTD.

**21** Years of Publishing Excellence

**5** Print Magazines

**6** Industry Portals

# INCREASE YOUR GROWTH WITH US !



**ENGINEERING REVIEW**  
Monthly magazine on manufacturing industry



**MACHINE TOOLS WORLD**  
Monthly magazine on machine tools & allied industry



**HEALTH & SAFETY**  
Monthly magazine on fire, safety & security industry



**PTR POWERTECH REVIEW**  
Bi-Monthly magazine on Electrical Equipments & Power Sector



**IAR INDUSTRIAL AUTOMATION REVIEW**  
Bi-Monthly magazine on Automation industry

[www.engmag.in](http://www.engmag.in) | [www.mtwmag.com](http://www.mtwmag.com) | [www.isrmag.com](http://www.isrmag.com)  
[www.powertechreview.com](http://www.powertechreview.com) | [www.industrialautomationreview.com](http://www.industrialautomationreview.com) | [www.cmhreview.com](http://www.cmhreview.com)

For branding & advertising opportunities call: +91 22 25380574 / 75 or email: [shekhar@divyamedia.com](mailto:shekhar@divyamedia.com)  
[www.divyamedia.com](http://www.divyamedia.com)

4<sup>th</sup>

# FSD EXPO

Fire + Safety + Disaster

[www.fsdexpo.in](http://www.fsdexpo.in)

06 - 07 JULY 2022,  
NEW DELHI, INDIA



# 4<sup>th</sup> FSD EXPO

(Fire + Safety + Disaster)

06 - 07 JULY 2022, Pragati Maidan, New Delhi, India

An International Exhibition on  
**Fire, Safety & Disaster Management**

Organised by:

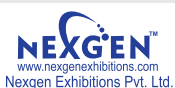

Supported by:



Media Partners:



**Contact Person:**

**Subhash Bhatt**

+91 7533018444 ✉ [subhash@nexgenexhibitions.com](mailto:subhash@nexgenexhibitions.com)



[/expofsd](https://www.facebook.com/expofsd)



[info@fsdexpo.in](mailto:info@fsdexpo.in)



+91-11-41536990

[www.fsdexpo.in](http://www.fsdexpo.in)



**INTERNATIONAL FIRE INDIA 2022**  
EXHIBITION & CONFERENCE



**15TH - 17TH  
SEPTEMBER 2022**

**HELIPAD EXHIBITION CENTRE,  
GANDHINAGAR, GUJARAT**

**16<sup>th</sup>  
Edition**



**HYBRID  
EXHIBITION**

**BOOK YOUR  
SPACE NOW**

**ORGANISED BY**

**CO-LOCATED EVENTS**

**FOR DETAILS CONTACT:**



**8800490372**

[privastava@servintonline.com](mailto:privastava@servintonline.com)

**9711361842**

[nlaroiya@servintonline.com](mailto:nlaroiya@servintonline.com)

**MEDIA PARTNERS**

**ONLINE MEDIA PARTNER**



**trade4india.com**

**www.fireindia.net**

# Ember Detector: Protecting Process Lines & Conveyor Belts from Fire Risks

**D**o you know that process lines and conveyor belts carry high risk of fire too? Especially in industries like Coal or Waste Recycling.

You never know when and where a fire accident can occur. And the source of the massive fire can be even a tiny object.

Conveyor belts in industries move materials from one process to the next process. For example, in Coal industry, coal is moved from one process to another & in Waste Recycling industry, object such as tramp metal, faulty batteries or smoldering material among other objects are moved through conveyer belts. There is a high possibility that there can be a hot or burning object lying hidden in between those materials. And if undetected, within minutes, a tiny fire or hot particle could have travelled all the way through the plant setting fire to other items on its way.

## So how do we control this risk? Answer is Ember Detector.

Ember detectors are extremely effective when scanning conveyor belts for hot particles. Rapid detection allows to contain the risk area and reduce the threat.

The word 'Ember' simply means a piece of wood or coal that continues to burn but has no flames. Hence any object that burns without flame is considered as an ember.

Ember detectors are more sensitive than flame detectors. They are designed uniquely to detect fire risks in transit. It is well suited for detection in conveyor belt application.

## How do Ember Detectors work?

**Ambetronics' Ember Detectors EMB-7700-FLP** give high speed detection using IR technology. It continuously scans for any hot or burning object among the materials moving over the conveyer belt or process line. As soon as it detects a hot or burning object, it generates an alarm alerting the workers. The detector can also be integrated with fire alarm control panel which will signal the conveyer belt or process line to stop moving so that the suspected object can be effectively disposed.

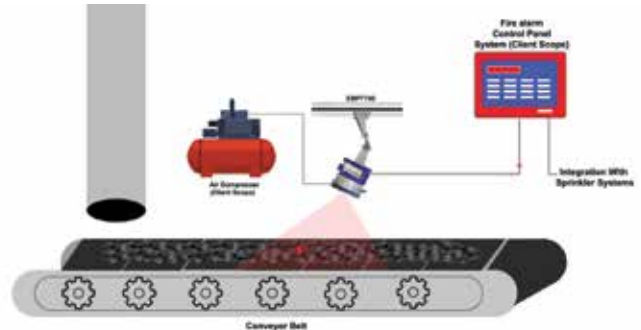
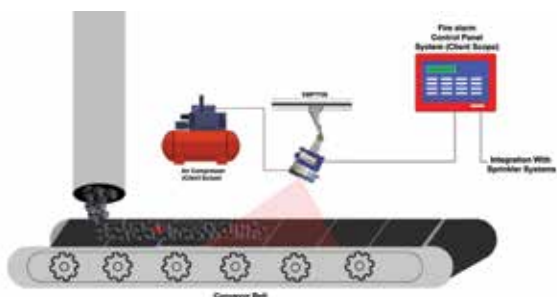

## Location of Installation:

The Ember Detector is to be installed at the beginning of a process line as well as at the end of a process line right before the start of another process for better detection. The location of installing also depends upon the length and width of the conveyer belt. If the conveyor is very long, then the detector needs to be installed at the mid-length also.

## Height of Installation:

The Ember Detector (EMB-7700-FLP) should be installed over the conveyer belt at a height of half the length of the width of the conveyer. That means Height of detector is equal to Half of conveyer belt Width. Simply put, Height = 1/2 Width

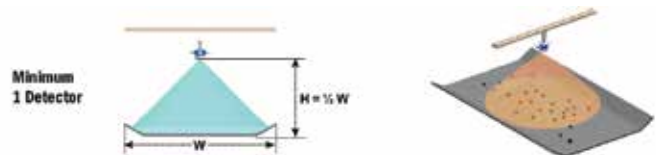

For enhanced detection, we recommend to install two numbers of Ember Detector over the Conveyor Belt. When installing two detectors, the height to install will become one third of the width of the conveyor belt. That means Height = 1/3 Width

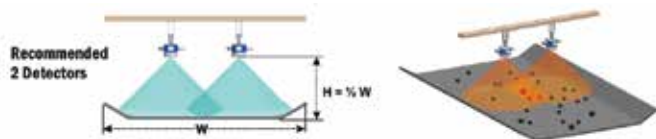

## Suitable applications of Ember Detector:

Conveyors, Silos, Waste Recycling Conveyors, Coal Dust Conveyance, Escalators, Drying Lines, Extractors, Production & Automation Industry, Waste Recycling Industry, Wood Industry: Sawdust Shavings, Textile Industry, Food Industry, Pharmaceutical & Chemical Industry. **ISR**

For more information

Email: [sales11@ambetronics.com](mailto:sales11@ambetronics.com)

Website: [www.ambetronics.com](http://www.ambetronics.com)





**Security  
And Fire  
Expo** South  
India

**6<sup>TH</sup> EDITION**

**informa markets**

**17 - 18 June 2022**  
Chennai Trade Center, Chennai

# SMART SOLUTIONS LEAD TO SMART CITIES

**FREE  
ENTRY**



Get one way reimbursement on your  
3 tier AC train fare to Chennai\*  
(First come - First serve basis)

## KEY PRODUCTS

  
Surveillance Cameras  
with Night Vision

  
Digital  
Video Recorders

  
Encoders &  
Decoders

  
Security Alarm  
Systems

  
Audio Video  
Door Phones

  
RFID  
Systems

  
Biometric  
System

  
Access  
Control

  
Electronic  
Locks

  
Entrance  
Management  
Solutions

  
IOT &  
Home Automation

  
GPS  
Tracking

  
Anti- Theft  
EAS Systems

  
Security  
Gates

  
Peripheral  
Accessories

  
Storage  
Devices

  
Perimeter Intrusion  
Detection Systems

  
Artificial  
Intelligence

  
UAV  
and Drones

### Premier Plus Partners



### Premier Partners



### Exhibiting Brands



### Knowledge Partner



### Supporting Associations



### Media Partner



Book Your Space:- Sanjeev Rao | M: +91 845293126 | E: Sanjeev.rao@informa.com  
Marketing & Alliances:- Pankaj Sharma | M: +91 9971365776 | E: Pankaj.sharma@informa.com

\*Condition apply

[www.safeindiaexpo.com](http://www.safeindiaexpo.com)



# Does Menstrual Cup affect the hymen?

**T**he female body is beautifully complex. Inside this beautiful body, there is a thin tissue located at the opening of the vagina known as hymen. Everybody is different and so is the tissue. Some bodies have extremely small tissues that it seems like they do not even have a hymen. These tissues can break or stretch even if some minor physical activities are performed like horse riding, swimming, stretching, and gyming or even while performing yoga. And in some cases, the hymen remains unaffected even after having sexual intercourse.



As mentioned above, this concept has a couple of flaws, and so does the idea of “breaking your hymen”. Time to clear up a couple of misconceptions about the hymen:

## The hymen does not seal the vagina:

It's important to highlight that it only partially covers the vagina because when the women's starts menstruating, the menstrual fluid pass through the vagina. It's one of the biggest misconceptions that the hymen fully “seals” the opening of the vagina. But if that was the case, then “virgins” couldn't menstruate, right?

## Every women's vagina and hymen is the different:

The hymen can look very different from person to person. The membrane can have many different shapes, some covers more of the opening of the vagina than others. Some are born with a small hymen (meaning it doesn't cover as much of the vagina), and some are even born without a hymen also.

## The hymen doesn't have to be broken:

As mentioned above, the hymen is a membrane that partially covers the vagina. It does not have to be popped, ripped or poked. It's pretty elastic type and if your body feels ready to have sex, the penis should simply be able to slide past the hymen, stretching it, but not ripping it.

Same thing goes when you insert your period product. When you're careful enough, you will simply be able to



push it past your membrane.

## Menstrual cups and hymens - do menstrual cups break virginity?

The most common understanding of “being a virgin” is an intact hymen. That's why many menstrual cup first time users are always afraid that introducing an internal period product can break their hymen, which is often understood as “losing virginity”. This myth persists even today, but research has found that the hymen is actually just made up of thin folds of tissue that typically wear away naturally as we go through adolescence. By the time you begin menstruating your hymen generally has holes already, and in many cases is almost gone (as shown in the image). This means that using a cup should have very little effect on your hymen, and in most cases, shouldn't affect you at all.

Using a menstrual cup can interfere with the hymen, as can a tampon. The hymen can also “break” from doing yoga, dancing, riding a bike etc. simply living a normal life. If your hymen was stretched or ripped (it only rips when not being gentle), because of anything else than having sex, it does not mean you have lost your virginity in the most common understanding of the concept of virginity.

The type of menstrual product that a person uses shouldn't be dependent on their status of virginity or their age, but rather on their needs.

For example, if you have a heavy flow and a high cervix, that's an important consideration in choosing your menstrual product. The Imasafe™ Large cup can hold three times of what a super tampon or a pad can hold. So if you have a very heavy period, you should be able to use the product that is most convenient for you. [ISR](#)

### Author:

**Rutuja Sonawane**

Officer - Sales & Marketing (Tubing  
Pharma Division)

tubing@amipolymer.com

Ami Polymer Pvt Ltd.



### Co-Author:

**Chanchal Jangid**

Officer - Sales & Marketing  
Support2@amipolymer.com

Ami Polymer Pvt Ltd.

# 15th - 17th SEPTEMBER 2022

Helipad Exhibition Centre, Gandhinagar, Gujarat



Knock your Market at the upcoming edition of Drone Expo 2022. The Exclusive Show with latest products & technology right at the doorstep of buyers.

ORGANISED BY



Founded 1973

CO-LOCATED EVENTS



FOR DETAILS CONTACT:

9350230865

strivedi@servintonline.com

9354688923

arai@servintonline.com

MEDIA PARTNERS



ONLINE MEDIA PARTNER

trade4india.com

[www.droneexpo.in](http://www.droneexpo.in)

# Para-Aramid Knitted Gloves with Crinkled Latex Coating (Tuff Coat)



## Features & Benefits

Para Aramid Seamless Gloves combined with Crinkled Finish Latex Coating for secured grip in wet & dry condition. These gloves also provide excellent cut, abrasion & puncture resistance. Open Back for more air circulation & soft Para Aramid Lining for non irritation for long periods of wear.

## Application

- Metal/ Sheet Metal Handling & Fabrication
- Glass Handling & Manufacturing
- Sharp Edged Objects
- Automotive manufacturing
- Paper & Pulp Industries
- Ceramic Industries 

For more information  
Web:[www.marvelgloves.com](http://www.marvelgloves.com)



L1002 (blue/yellow)

L1001 (black/yellow)

L1001 (blue/yellow)



**FREE ENTRY**

# POWER OF OCCUPATIONAL SAFETY & HEALTH RETURNS

@

**OSH INDIA SOUTH**

**17 - 18 June 2022**

**Chennai**

**Chennai Trade Center**

## KEY PRODUCTS



## KEY FEATURES

### PRODUCT PROFILE



Explore personal protective equipment - safety wear, head/eye/hand protection, fall prevention, height safety, gas detectors, ergonomics, occupational health and many more safety products and services

### CONFERENCE



Rich content led knowledge forums bringing together eminent speakers from the safety industry

### PRODUCT LAUNCH PAD



Exclusive first look at occupational safety & health products and services as they hit the market

### LIVE DEMONSTRATIONS



Industry experts showcasing best practices and know-how that are vital for a safer work environment

### NETWORKING



One on one interactions with suppliers, manufacturers, distributors, key government officials, key association officials, and thought leaders from the safety industry

## KEY EXHIBITORS

### Gold Partners



### Silver Partners



### Key Branding Partner



### Conference Session Partner



### Emergency Response Partner



### QR Code Partner



**Get one way reimbursement on your 3 tier AC train fare to Chennai\***

**APPLY NOW**

\*Conditions apply

Contact:- Inteshar Memon | M: +91 70459 09099 | E: Inteshar.memon@informa.com

Media Partner



[www.oshindia.com](http://www.oshindia.com)

This is a Trade Show. Children Below 18 years of Age are not allowed. Rights of admission reserved with Informa Markets India Pvt. Ltd.

# Matrix Perimeter Security Solution



**P**erimeter security is the first line of defense to protect your assets, information, and people using advanced technology. Just as the human skin protects the body against the external environment and infections, the perimeter security system is designed to keep away unauthorized intrusion in your property.

Keeping that in mind, Matrix offers their Perimeter Security Solution to deter intrusions from happening by detecting them in real-time. With intelligent video analytics one can detect intruders in real-time and mitigate the threats easily.

The system has been designed to work with both Matrix network cameras as well as third-party cameras and ancillary devices such as motion detectors, electric fences, fire alarms, burglar alarms and more.

Again, the cognitive analytics ensure that there are no false alarms being detected

because of the camera events. Making the system a reliable security solution for your needs.

## KEY FEATURES:

- Intrusion Detection, Tripwire Detection
- Integration with Motion Sensors, Fire Alarms, Burglar Alarms
- Integration with parent and third-party cameras
- Real-time Notifications
- Cognitive Analytics - No False Notifications

**ISR**

For more information  
[https://www.matrixvideosurveillance.com/perimeter-security.html?utm\\_medium=product%20news&utm\\_source=PR&utm\\_campaign=Industrial%20Safety%20Review](https://www.matrixvideosurveillance.com/perimeter-security.html?utm_medium=product%20news&utm_source=PR&utm_campaign=Industrial%20Safety%20Review)





**SAFETYEX**  
exhibition



India's Comprehensive Safety Products,  
Services & Training Event

**15<sup>th</sup> – 17<sup>th</sup>  
September 2022**  
**Helipad Exhibition Centre,  
Gandhinagar, Gujarat**

**HYBRID EXHIBITION**

ORGANISED BY

CO-LOCATED EVENTS

FOR DETAILS CONTACT:



**8800490372**  
psrivastava@servintonline.com

**9711361842**  
nlaroiya@servintonline.com

MEDIA PARTNERS

ONLINE MEDIA PARTNER



trade4india.com

[www.safetyex.in](http://www.safetyex.in)

# COMMON SENSE FIRE SAFETY: FIRE ACCIDENTS NEED TO BE PREVENTED FROM OCCURRING IN THE FIRST PLACE

**W**hen we talk of fire safety, we actually need to be ahead of the incidents to effectively tackle fire accident tragedies. This means taking pro-active steps to prevent fire from doing damage in the first place. This is the reality that people tend to ignore or overlook.

In the corona pandemic we saw that whatever had to be done to stem the root had to be done by the last man upwards. It took a major fear complex that drove everyone to wear masks, sanitize, keep safe distance, go for tests etc. But not before many succumbed and the lockdown, lathi measures took precedence over coaxing, cajoling and requesting.

Barely hours after Prime minister Narendra Modi asked states to undertake fire audits, especially of hospitals, citing rising cases of such incidents amid searing heat in many parts of the country, The Department of Delhi Fire Services revealed it had received around 3,500 odd fire and emergency-related calls, including cases of house collapses, since April 1 and that it would start the audit process soon.

"We have been directed by the Delhi government to conduct a fire audit of the 38 government-run hospitals for now. But we will be conducting audits in all the hospitals. In case we find any default in their fire safety system, shortcomings will be highlighted, and accordingly, they will have to take corrective measures," a senior fire official said.

The question to ask, cynical as it may sound, is did this wisdom dawn upon the fire chief only now? To be fair, the fire departments in most parts of the country conduct awareness programs, mock drills, training sessions and similar things regularly, but unfortunately, a new film attracts far bigger crowds than these programs do. Then the theatre catches fire. Now, that was a bit tongue in cheek, but remember Uphaar?

The cinema hall was shut in 1997 after a major fire broke out with nearly about 150 moviegoers trapped inside. Now read this

April 17th news report:

"A minor fire broke out inside Uphaar Cinema theatre on Sunday morning, following which five fire tenders rushed to the spot. No casualties have been reported till now. The blaze affected the theatre's balcony and a floor." There is a hidden

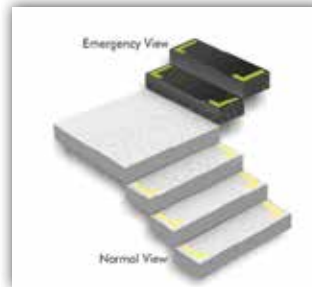

irony here. The place with a historic fire tragedy reputation is on fire after 25 plus years repeats the history. No deaths this time, but the level of forgetfulness and carelessness on everyone's part tells a story. What if the cinema hall was opened and a show was on this time too?

The challenge today has multiplied, especially in locations where the proportion of visitors unfamiliar with layout and procedures increase. In enclosed spaces, exigency products and protocols need to be upgraded regularly while in open spaces like highly-populated, high-risk or complex premises such as railway stations, shopping centres, airports, stadia, government buildings or leisure facilities way finding signages and related products need to be updated and improved upon periodically.

Emergency lighting is a lifesaver in hazardous situations. Crucially, it enables the safe, prompt and efficient evacuation of spaces and buildings, not just in cases of blackouts or power outages, but in situations where sunlight and mains lighting may be unavailable or weak. An effective emergency lighting system guides people in and around enclosed and open environments as well. These lights help them locate safety equipment, refuge and assembly points and also spot obstacles or hindrances in the way of quick exigency. Most importantly, Prolite manufactures products conversant with the latest requirements as per the NBC or related licencing authorities so with Prolite products, getting a fire licence which is crucial for any enclosed premise, becomes easy and smooth everytime.

Prolite Autoglo has its hands firmly on the pulse of the people and legs on the gas pedal when it comes to providing the above facilities. Prolite's emergency lighting systems and photoluminescent signages are always the best available option in tricky situations and now, with its robust entry into the way finding segment, the same commitment to quality and trend setting innovation is on display here as well. [ISR](#)

**PROLITE**  
**AUTOGLO**

For more information  
E-mail: [sales@prolite.in](mailto:sales@prolite.in)  
Web: [www.prolite.in](http://www.prolite.in)

# Parking Space Barrier

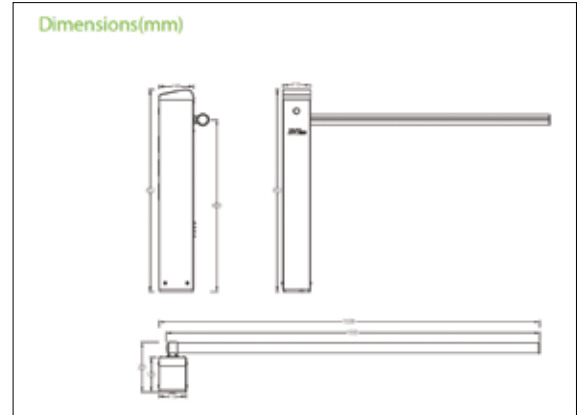

efficiency motherboard.

ZYVIP L/R series are suitable for various scenarios, such as lower ground level car park and electric vehicle charging station parking space management. Also, ZYVIP L/R series is suitable for apartments, schools, and sidewalks access control.

**Z**KTeco's ZYVIP L/R series adopts an advanced surface treatment technology, offers a unique and elegant outlook. The operation of this parking space barrier stable and durable because it uses a DC 24V brushless motor and a high-

**Specifications**

Model	ZYVIP L/R
Operating Speed	3s to 15s (adjustable)
Boom Arm Length	1.5m
Boom Arm Type	Round boom with LED light
Chassis Dimension (L*W*H)	140*110*110 (mm)
Chassis Weight	12kg
Motor Type	DC 24V brushless motor
Motor MCF	1 Million
Output Power	45W
Rated Current	2A
Power Supply	AC 220V/50Hz
Remote Control Distance	±30m
Operating Temperature	-10°C to +60°C
Operating Humidity	≤90%RH
Chassis Housing Material	304# Stainless steel

**Features**

- Elegant design with a solid chassis
- Operation speed as fast as 3s
- Embedded LED lighting
- Adjustable boom arm angle of rise and fall
- DC 24V brushless motor
- Automatic obstacle detection
- Anti-smashing function
- Automatic delay closing

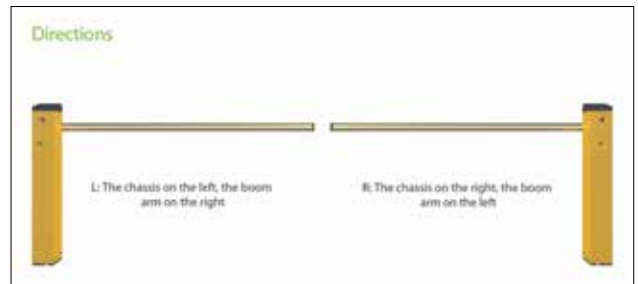

For more information  
Web: [www.zkteco.in](http://www.zkteco.in)

## Parking Space Barrier ZYVIP L/R Series

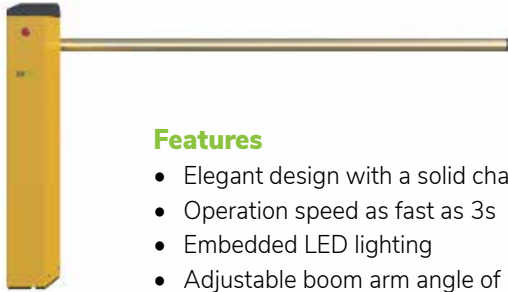

### Features

- Elegant design with a solid chassis
- Operation speed as fast as 3s
- Embedded LED lighting
- Adjustable boom arm angle of rise and fall
- DC 24V brushless motor
- Automatic obstacle detection
- Anti-smashing function
- Automatic delay closing. **ISR**

## LPRC300 license plate recognition camera



### Features

- Embedded Deep Learning LPR Algorithm
- AI Chip with 0.5 TOPS
- Embedded Allowlist and Blocklist
- ONVIF Protocol, for Video Surveillance
- Free SDK and push protocol supporting 3rd-party integration. Card Holders Capacity-30,000
- 3 Mega pixel camera. **ISR**

## EFace10 Touchless Multi-Biometric Identification Terminal

### Features

- Visible Light facial recognition
- Anti-spoofing algorithm against print attack (laser, color and B/W photos), videos attack and 3D mask attack
- Multiple verification methods: Face / Password / Card (optional)
- Card modules (optional): 125KHz ID Card (EM) / 13.56MHz IC Card
- Backup rechargeable battery (optional): offers at least 2 hours of power on a full charge, and it takes 4 hours to recharge
- Support standard wall-mounting with Backplate or optional wall-mounting with Cable Box, and optional desktop installation with Cable Box **ISR**



## MiniAC Plus Linux-Based Access control and Time & Attendance Terminal with Visible Light Facial recognition

### Features

- Visible Light Facial Recognition
- Anti-spoofing algorithm against print attack (laser, color and B/W photos), videos attack and 3D mask attack
- Multiple Verifications: Face / Palm / Card / Password
- Multiple card modules: 125KHz ID card (EM) / 13.56MHz IC card (MF)
- 3,000 face templates capacity **ISR**



**ZKTeco**

For more information  
Web: [www.zkteco.in](http://www.zkteco.in)

# SUBSCRIBE

## NOW !!!



**INDUSTRIAL HEALTH & SAFETY REVIEW** has exclusive 360° focus on various facets of health, safety, fire & security industry; every month it covers exclusive articles, industry news, technical information, product updates, and interviews. Hence **INDUSTRIAL HEALTH & SAFETY REVIEW** becomes ready reckoner for every Safety Officer, Security Manager, Fire Engineers, Facility Managers, EHM heads, System Integrator on the job. **INDUSTRIAL HEALTH & SAFETY REVIEW** magazine is one stop shop solution all your health, safety, fire & security related information needs and is useful knowledge manual for implementing latest technology in existing setup or infrastructure.



### PRINT MAGAZINE SUBSCRIPTION RATES

YEARS	ISSUES	AMOUNT
One Year	12 Issues	INR Rs. 3000/-
Two Years	24 Issues	INR Rs. 6000/-
Three Years	36 Issues	INR Rs. 9000/-

### DIGITAL MAGAZINE SUBSCRIPTION RATES

YEARS	ISSUES	AMOUNT
One Year	12 Issues	INR Rs. 500/-
Two Years	24 Issues	INR Rs. 1000/-
Three Years	36 Issues	INR Rs. 1500/-

#### Important terms & conditions for Subscribers:

- \* Non receipt of magazine - Subscriber has to launch a complaint of non-receipt of magazine in writing at [subscription@divyamediaonline.com](mailto:subscription@divyamediaonline.com) within 15 days of dispatch schedule (mentioned in Printing & Dispatch term).
- \* New subscriber - For the new subscribers, subscription period will be effective from the coming month magazine under print as per Printing & Dispatch term.
- \* International mailing - For international subscribers, magazine will be sent through Indian Postal Department service- "PRINTED BOOKS BY REGISTERED POST"

#### DIVYA MEDIA PUBLICATIONS PVT. LTD.

303/304, 3rd Floor, Harmony Tower, Netaji Subhash Road, Court Naka, Thane (W), Maharashtra - 400 602, India.  
Tel.: +91 22 25380574/75, Telefax: +91 22 25418254, Email: [subscription@divyamediaonline.com](mailto:subscription@divyamediaonline.com), Website: [www.isrmag.com](http://www.isrmag.com)

## Matrix 2MP Pan-Tilt-Zoom Camera with 33x Optical Zoom



The scope of surveillance has moved beyond its traditional purpose. Surveillance is no longer just about managing the threat; it is about increasing productivity, managing connected spaces and deriving insights from the business. Simultaneously, the cost of surveillance is increasing day by day.

Not just organizations but also public authorities are in need for surveillance devices to control public spaces that are heavily crowded. To solve these surveillance backdrops, Matrix offers its Pan-Tilt- and Zoom camera that has been designed for 360° surveillance.

The cameras are a blend of performance and sturdy design. Powered using back-illuminated Sony STARVIS series sensors, the cameras offer superior image quality in low-light conditions. Apart from this, image enhancing technologies make sure the image clarity is constant in varying light conditions. Also, the cameras offer infrared sensors that provide night vision up to 200 metres.

Next, the 360° Pan Range make sure that you can monitor large areas easily without the need for additional cameras. Again, offering optical zoom up to 33 times you can zoom into details with a single click. Finally, offering a sturdy built, the cameras can withstand external impacts (IK10 Certified). Likewise, they can withstand harsh weather conditions (IP67 - Ingress Protection)

### KEY FEATURES:

- 33x Optical Zoom and 16x Digital Zoom
- 1920 x 1080 Resolution
- True WDR (140dB)
- H.265 Video Compression Technology
- 256GB Edge Storage
- 8 Automatic Scans
- 500 Presets
- Intelligent Video Analytics **ISR**

For more information  
<https://www.matrixvideosurveillance.com/>

## Matrix 8MP Project Series Dome IP Camera

Matrix Project Series Dome Cameras are designed to meet the needs of large enterprises and project environments. Designed for both indoor and outdoor surveillance needs the cameras are suited for modern organizations. Powered with Sony STARVIS sensors the cameras offer exceptional low-light performance. Apart from this, the cameras are developed with technologies to enhance the image quality. Besides this, image enhancing technologies such as True WDR help to balance the image lighting.

Further, dome cameras offer a sturdy built which allows them to perform exceptionally in harsh weather conditions as well as external impacts. The cameras are offered in fixed and motorized varifocal lens which gives the user the option to zoom in and out of the video

footage.

### KEY FEATURES:

- Low - light Image Quality - 0.01 Lux
- H.265 Compression Technology
- Superlative Image with WDR (120dB)
- Adaptive and Smart Streaming
- Higher Signal to Noise Ratio (>70dB)
- Higher Field of View (HFOV: 106.9°)
- Intelligent Video Analytics
- Ingress Protection - IP67 Certified
- Impact Protection - IK10 Certified **ISR**



For more information  
<https://www.matrixvideosurveillance.com/>

# Matrix COSEC VEGA CAX



With the passing of time, the necessity of security to inculcate flexibility in its design and working became more important than having rigid standalone networks. Matrix COSEC VEGA CAX brings huge flexibility to the time attendance and access control needs of an organization.

Built with precision engineering methods to combine aesthetics, connectivity, and reliability, Matrix COSEC VEGA CAX is the perfect product for the Access Control and Time-Attendance needs of any

modern organization regardless of the operational size.

With multi-credential support and multi-connectivities, it easily integrates into the security framework of any organization. With features such as IP65 certified, PoE, WiFi, touchscreen, it becomes the ultimate product to manage multiple solutions beyond access control and time attendance for modern organizations.

### KEY FEATURES:

- Multiple User Credential - BLE,

RFID, PIN, FACE

- Massive Storage Capacity - 50,000 Users Profiles, 5,00,000 Events
- Multiple Connectivity Options - Ethernet, PoE, Wi-Fi, Mobile Broadband
- Auxiliary Ports for Integration with Alarms and Panels
- Built-in APIs to Communicate with Third-party Software. 

For more information  
[www.matrixaccesscontrol.com](http://www.matrixaccesscontrol.com)

## AD INDEX

COMPANY NAME	PG. NO.	COMPANY NAME	PG. NO.	COMPANY NAME	PG. NO.
A		K		S	
AGNI CONTROLS CHENNAI	18	KIMBERLY-CLARK WORLDWIDE, INC.	15	SAFESTART	INNER INSIDE FALSE COVER
AMBETRONICS ENGINEERS PVT. LTD.	27	L		SAFETYEX - 2021	51
AMI POLYMER PVT. LTD.	19	LIBERTY SHOES LTD.	7	SCRUM SYSTEM	33
D		M		SECURITY AND FIRE EXPO - 2022	45
DELTA PLUS GROUP	5	MARVEL GLOVES INDUSTRIES	37	SHAH BHOGILAL JETHALAL & BROS.	21
DISASTER RESPONSE & MANAGEMENT EXPO - 2022	58	MATRIX SECURITY SOLUTIONS	1	SHENG YI TECH & ANALYTICS CO., LTD.	BACK PAGE
DRONE EXPO - 2022	47	MN RUBBER PVT. LTD.	35	SURE SAFETY (INDIA) PVT. LTD.	17
E		O		V	
EURO SAFETY GROUP	INSIDE FRONT COVER	OSH INDIA - SOUTH - 2022	49	VICTOR IMPORTS	23
F		P		Z	
FIRE INDIA - 2022	43	PRAMA HIKVISION INDIA PVT. LTD.	FRONT COVER	ZKTECO BIOMETRICS INDIA PVT LTD	FRONT GATEFOLD
FSD EXPO - 2022	42	P		Z	
H		PROLITE AUTOGLO LIMITED	3	Z	
HD FIRE PROTECT PVT. LTD.	INSIDE BACK COVER	P		Z	

# DISASTER

RESPONSE & MANAGEMENT  
exhibition & conference

15<sup>th</sup> – 17<sup>th</sup>  
**September 2022**  
Helipad Exhibition Centre,  
Gandhinagar, Gujarat



HYBRID  
EXHIBITION



**BOOK YOUR SPACE NOW**

ORGANISED BY

CO-LOCATED EVENTS

FOR DETAILS CONTACT:



8800490372

psrivastava@servintonline.com

9711361842

nlaroia@servintonline.com

MEDIA PARTNERS

ONLINE MEDIA PARTNER



trade4india.com

[www.disasterexpo.com](http://www.disasterexpo.com)



# Introducing HD Inert Gas and CO2 Fire Suppression Systems



- ▶ Designed for:  
IG55 (Argon and Nitrogen),  
IG541 (Nitrogen IG100,  
Argon IG01 and Carbon dioxide),  
IG100 (Nitrogen) and IG01 (Argon)
- ▶ Cylinder Sizes: 80 and 140 litre
- ▶ Operating Pressure: 200/300 bar
- ▶ Releasing Device: Manual,  
Pneumatic, Electro-Magnetic
- ▶ Diffuser nozzles in brass  
construction
- ▶ Approval: VdS

## *"HD-RAKSHAK" Indirect CO2 Electrical Cabinet Fire Suppression System*



- ▶ Cylinder Sizes: 2 to 45 kg
- ▶ Operation Pressure: 60 bar
- ▶ Automatic IHP valve in  
brass construction
- ▶ UL Listed fire detection tubing
- ▶ No need to charge the  
detection tube with  
additional N2 cylinder
- ▶ System in compliance  
with IS-15528.2004

## *"HD-INERTSYS" Inert Gas Fire Suppression System*

**HD FIRE PROTECT PVT. LTD.**

D-6/2, Road Number 34, Wagle Estate, Thane 400604, India  
Tel: +(91)22 21582600 Fax: +(91)22 21582602 Email: info@hdfire.com www.hdfire.com



**mPower Electronics**

*Making Powerful Senses*



## **Portable Multi-gas Detector**

**Pump & Diffusion type**

Man-Down Alarm with real-time wireless notification

## **Portable Single Gas Detector**

**Battery Replaceable & Disposal type**

Sensors for over 20 chemicals in 30 concentration ranges



## **PID Detector for VOC**

**Portable & Fixed type**

1 ppb VOC resolution  
VOC emission monitoring

## **Portable Wireless Gas Detection System**

Remote, wireless real-time readings  
including Man-down alarms



**mPower Master Distributor for Asia Market**  
**Sheng Yi Tech & Analytics Co., Ltd.**

Email : [oversea@shengyi.com.tw](mailto:oversea@shengyi.com.tw)  
<https://www.shengyi.com.tw/en>

<https://www.mpowerinc.com>

mPower Web

